

T100 SERIES

OEM Linear Slide | Accessories

T110-06M	Part Number	Qty/Unit
M5 Adjustable Flow Control, 6mm OD Tube	VLVF-008	1-2
Stop Kit, Adjustable, Extend	OSAK-088	1
Stop Kit, Adjustable, Retract	OSAK-094	1
Seal Repair Kit (includes: Piston Seal, Retainer C-clip, Rod Seal, O-ring, Bumper)	SLKT-248	1

T110-08M	Part Number	Qty/Unit
M5 Adjustable Flow Control, 6mm OD Tube	VLVF-008	1-2
Stop Kit, Adjustable, Extend	OSAK-089	1
Stop Kit, Adjustable, Retract	OSAK-095	1
Shock Absorber Kit, Extend	OSAK-123	1
Shock Absorber Kit, Retract	OSAK-128	1
Spare Shock Absorber	SHOK-057	1
Seal Repair Kit (includes: Piston Seal, Retainer C-clip, Rod Seal, O-ring, Bumper)	SLKT-249	1

T110-12M	Part Number	Qty/Unit
M5 Adjustable Flow Control, 6mm OD Tube	VLVF-008	1-2
Stop Kit, Adjustable, Extend	OSAK-090	1
Stop Kit, Adjustable, Retract	OSAK-096	1
Shock Absorber Kit, Extend	OSAK-124	1
Shock Absorber Kit, Retract	OSAK-129	1
Spare Shock Absorber	SHOK-057	1
Seal Repair Kit (includes: Piston Seal, Retainer C-clip, Rod Seal, O-ring, Bumper)	SLKT-250	1

T110-16M	Part Number	Qty/Unit
M5 Adjustable Flow Control, 6mm OD Tube	VLVF-008	1-2
Stop Kit, Adjustable, Extend	OSAK-091	1
Stop Kit, Adjustable, Retract	OSAK-097	1
Shock Absorber Kit, Extend	OSAK-125	1
Shock Absorber Kit, Retract	OSAK-130	1
Spare Shock Absorber	SHOK-059	1
Seal Repair Kit (includes: Piston Seal, Retainer C-clip, Rod Seal, O-ring, Bumper)	SLKT-251	1

T110-20M	Part Number	Qty/Unit
G1/8 Adjustable Flow Control, 6mm OD Tube	VLVF-005	1-2
Stop Kit, Adjustable, Extend	OSAK-092	1
Stop Kit, Adjustable, Retract	OSAK-098	1
Shock Absorber Kit, Extend	OSAK-126	1
Shock Absorber Kit, Retract	OSAK-131	1
Spare Shock Absorber	SHOK-060	1
Seal Repair Kit (includes: Piston Seal, Retainer C-clip, Rod Seal, O-ring, Bumper)	SLKT-252	1

T110-25M	Part Number	Qty/Unit
G1/8 Adjustable Flow Control, 6mm OD Tube	VLVF-005	1-2
Stop Kit, Adjustable, Extend	OSAK-093	1
Stop Kit, Adjustable, Retract	OSAK-099	1
Shock Absorber Kit, Extend	OSAK-127	1
Shock Absorber Kit, Retract	OSAK-132	1
Spare Shock Absorber	SHOK-061	1
Seal Repair Kit (includes: Piston Seal, Retainer C-clip, Rod Seal, O-ring, Bumper)	SLKT-253	1

Dimensions and technical information are subject to change without notice

GR-OEM-16



T100 SERIES

OEM Linear Slide | Quick Installation Kits

Commissioning Kits for Easy Ordering

- Includes just what you need for easy installation
- One quick installation kit required per slide
- Fast, simple convenient ordering



Sensors



Cables



Adjustable Flow Controls



Shock Kit, Retract

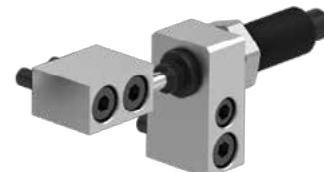

Shock Kit, Extend

T110-06M	Includes	Part Number	Qty/Kit
Sensors, PNP Magneto Resistive Type, 4mm Barrel	OHSP-021	T110-QKST-101	2
Quick Disconnect 2 Meter Cable Length	CABL-010		2
Adjustable Flow Control, M5, 6mm OD Tube	VLVF-008		2
T110-08M	Includes	Part Number	Qty/Kit
Sensors, PNP Magneto Resistive Type, 4mm Barrel	OHSP-021	T110-QKST-102	2
Quick Disconnect 2 Meter Cable Length	CABL-010		2
Adjustable Flow Control, M5, 6mm OD Tube	VLVF-008		2
Shock Absorber Kit, Extend	OSAK-123		1
Shock Absorber Kit, Retract	OSAK-128		1
T110-12M	Includes	Part Number	Qty/Kit
Sensors, PNP Magneto Resistive Type, 4mm Barrel	OHSP-021	T110-QKST-103	2
Quick Disconnect 2 Meter Cable Length	CABL-010		2
Adjustable Flow Control, M5, 6mm OD Tube	VLVF-008		2
Shock Absorber Kit, Extend	OSAK-124		1
Shock Absorber Kit, Retract	OSAK-129		1
T110-16M	Includes	Part Number	Qty/Kit
Sensors, PNP Magneto Resistive Type, 4mm Barrel	OHSP-021	T110-QKST-104	2
Quick Disconnect 2 Meter Cable Length	CABL-010		2
Adjustable Flow Control, M5, 6mm OD Tube	VLVF-008		2
Shock Absorber Kit, Extend	OSAK-125		1
Shock Absorber Kit, Retract	OSAK-130		1
T110-20M	Includes	Part Number	Qty/Kit
Sensors, PNP Magneto Resistive Type, 4mm Barrel	OHSP-021	T110-QKST-105	2
Quick Disconnect 2 Meter Cable Length	CABL-010		2
Adjustable Flow Control, G1/8, 6mm OD Tube	VLVF-005		2
Shock Absorber Kit, Extend	OSAK-126		1
Shock Absorber Kit, Retract	OSAK-131		1
T110-25M	Includes	Part Number	Qty/Kit
Sensors, PNP Magneto Resistive Type, 4mm Barrel	OHSP-021	T110-QKST-106	2
Quick Disconnect 2 Meter Cable Length	CABL-010		2
Adjustable Flow Control, G1/8, 6mm OD Tube	VLVF-005		2
Shock Absorber Kit, Extend	OSAK-127		1
Shock Absorber Kit, Retract	OSAK-132		1



GR-OEM-17

Dimensions and technical information are subject to change without notice

T100 SERIES

OEM Linear Slide | Accessories Dimensions

Shock Absorbers

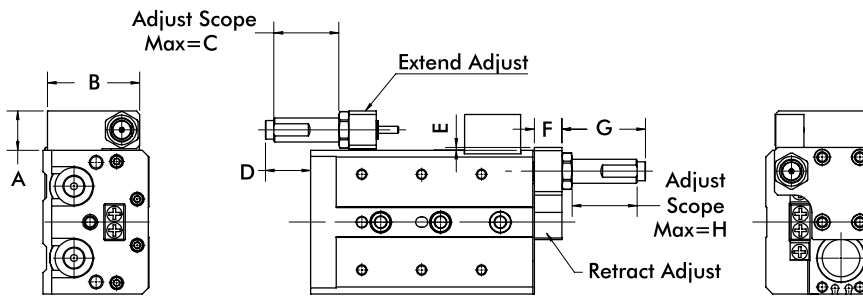
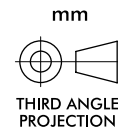
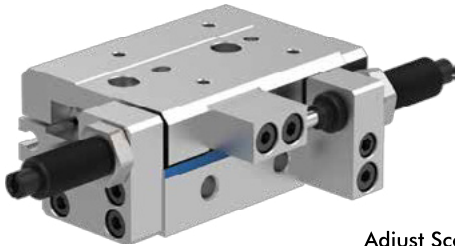

For Model No.	A	B	C	D	E	F	G	H
T110-08M	13	22.5	18.5	18.5	0.1	8.5	28.5	19.5
T110-12M	14.5	29.5	17.5	15	0.5	11	26	17
T110-16M	16.5	37.7	25	18.5	1.5	12	35	26
T110-20M	21	46.5	23.5	14.5	0.5	15	34	25
T110-25M	23	56.5	37.5	26	1.8	16	49	38

Stop Kits

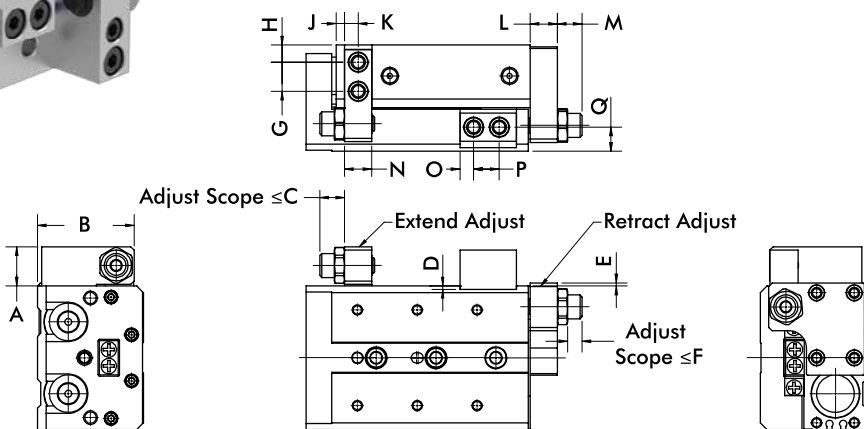
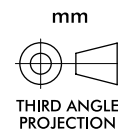

For Model No.	A	B	C	D	E	F	G	H	J	K	L	M	N	O	P	Q
T110-06M	10	20	5	0.5	--	10	5.5	3	2	3.5	7	13.5	7	3	6.5	5
T110-08M	13	22.5	7	0.5	--	7.5	6.5	4	2	4.5	8.5	11	8.5	4	7	5.5
T110-12M	14.5	30	6	1	1.4	5	8	5.5	2	5.5	11	9.5	11	6	8.5	7
T110-16M	16.5	37.5	6	--	1.5	6.5	11	6.5	3	6	12	11	12	6.5	10	7.5
T110-20M	21	46.5	6.5	1.5	1	7.5	13.5	8	3	7.5	15	12	15	6.5	12	12
T110-25M	23	56.5	8.5	2	1.8	8.5	17	10	5	8	16	15	16	8	15	14

Dimensions and technical information are subject to change without notice

GR-OEM-18



T110-06M

OEM Linear Slide | Dimensions and Technical Specifications

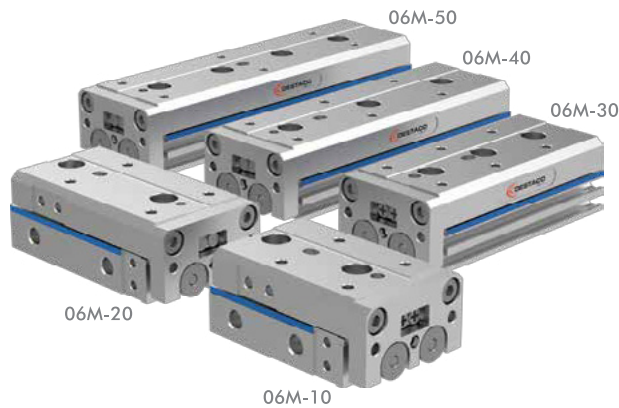

Specifications	Units	06M	
Thrust Force at 7 bar [100 psi]	Retract	N [lbf]	29 [6.51]
	Extend		40 [9.0]
Pressure Range	bar [psi]	1.5-7 [22-100]	
Cylinder Bore Diameter [x2]	mm [in]	6 [0.23]	
Speed Range	mm/sec [in/sec]	50-500 [2-20]	
End Stop Repeatability, Basic Unit	mm [in]	±0.5 [±0.02]	
End Stop Repeatability, Stop Kit	mm [in]	±0.2 [±0.01]	
End Stop Repeatability, Shock Kit	mm [in]	±0.02 [±0.001]	
Valve Required to Actuate		4 Way 2 Position	

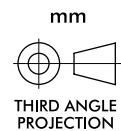
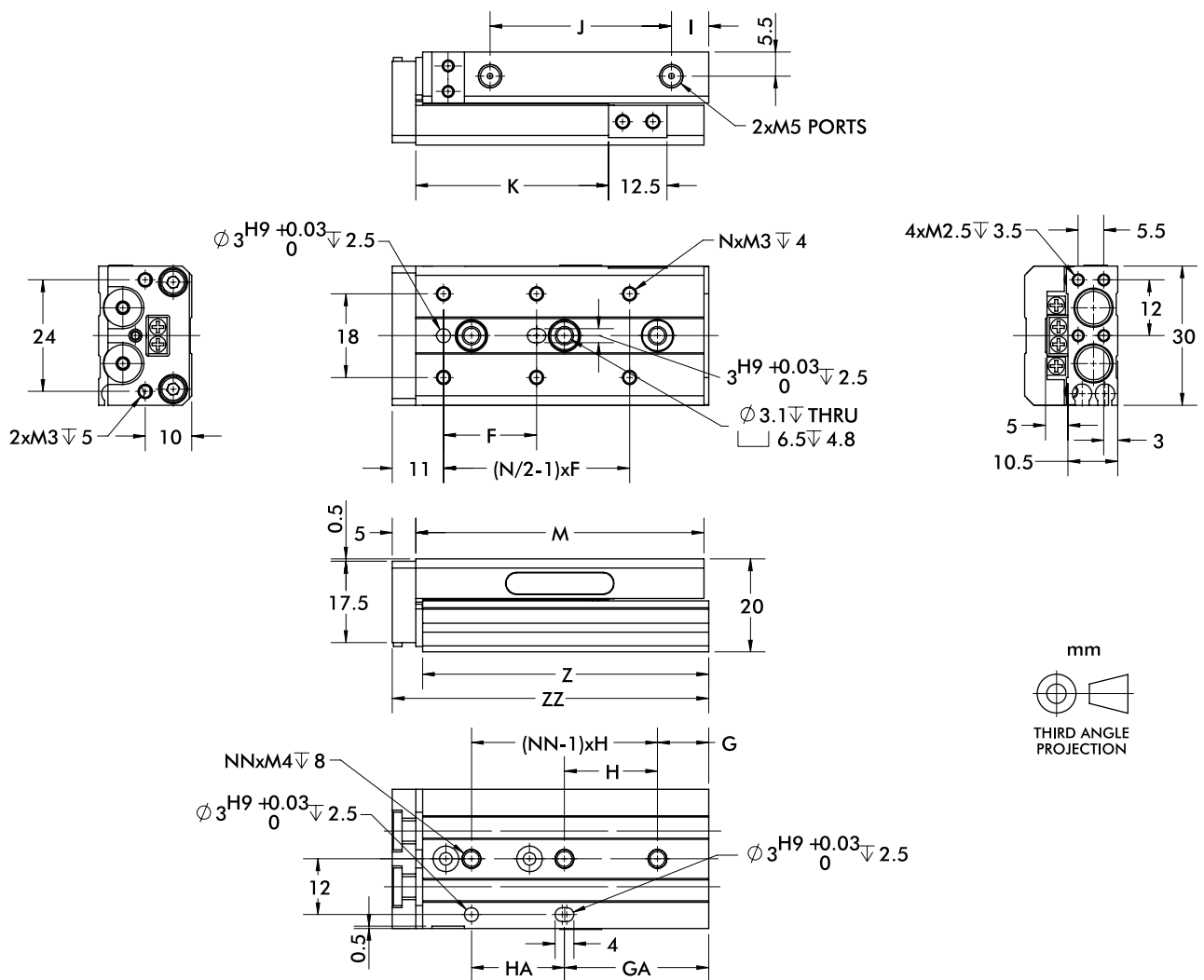

Stroke\Item	F	N	G	H	NN	GA	HA	I	J	K	M	Z	ZZ
10	20	4	6	25	2	11	20	8	19	21.5	42	41.5	48
20	30	4	6	35	2	21	20	9	28	31.5	52	51.5	58
30	20	6	11	20	3	31	20	8	39	41.5	62	61.5	68
40	28	6	13	30	3	43	30	18	51	51.5	84	83.5	90
50	38	6	17	24	4	41	48	24	61	61.5	100	99.5	106



GR-OEM-19

Dimensions and technical information are subject to change without notice

T110-06M

OEM Linear Slides | Technical Specifications

Specifications	Units	06M-10	06M-20	06M-30	06M-40	06M-50
Stroke	mm (in)	10 [0.39]	20 [0.79]	30 [1.18]	40 [1.57]	50 [1.97]
Weight	kg (lb)	0.08 [0.178]	0.1 [0.222]	0.12 [0.256]	0.16 [0.344]	0.18 [0.4]
Displacement	cc (cu-in)	0.57 [0.035]	1.13 [0.069]	1.70 [0.104]	2.26 [0.138]	2.83 [0.173]
Max. Applied Load	N (lbf)	5 [1.124]	5 [1.124]	5 [1.124]	5 [1.124]	5 [1.124]

Deflection

(Note: Moment calculations located on page 31)

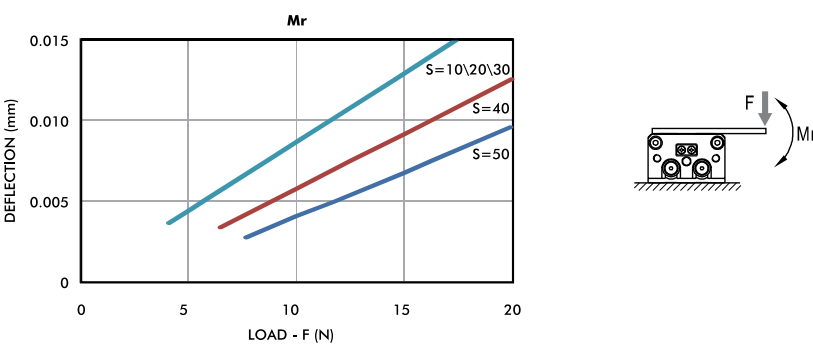
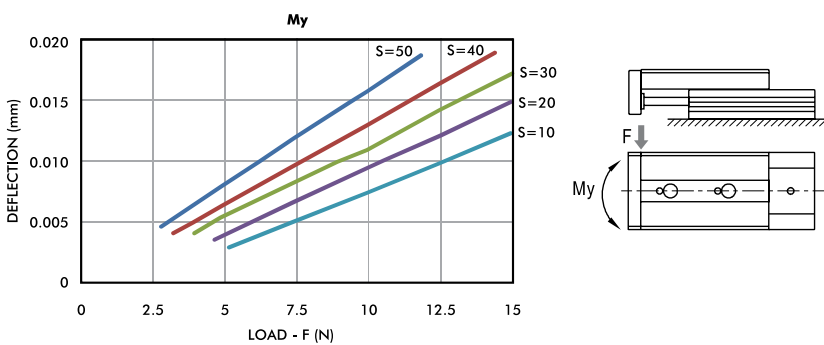
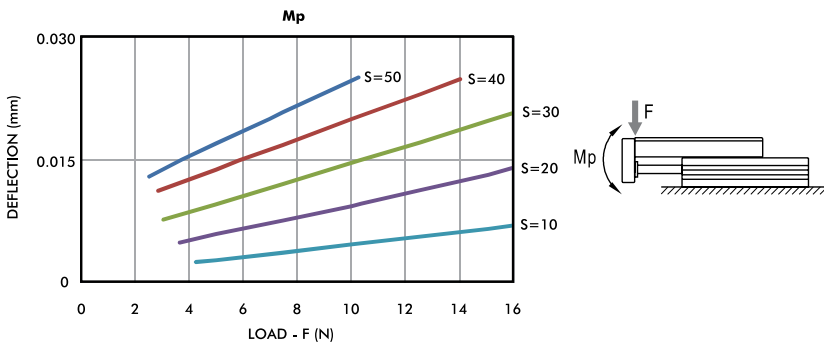

Payload vs. Velocity

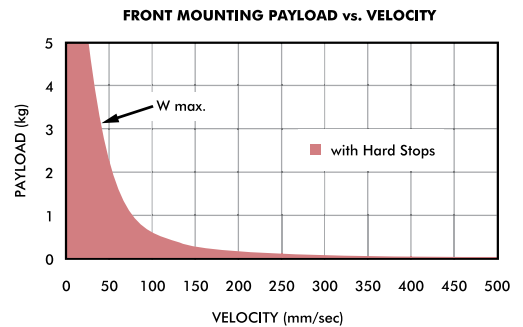
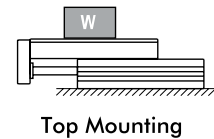
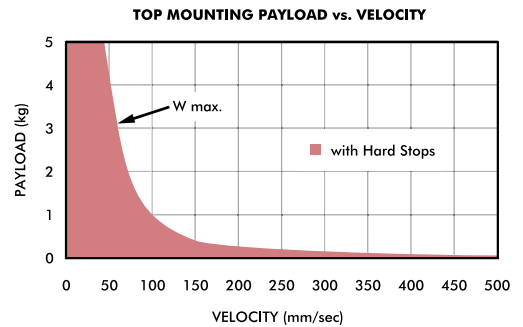

T110-08M

OEM Linear Slide | Dimensions and Technical Specifications

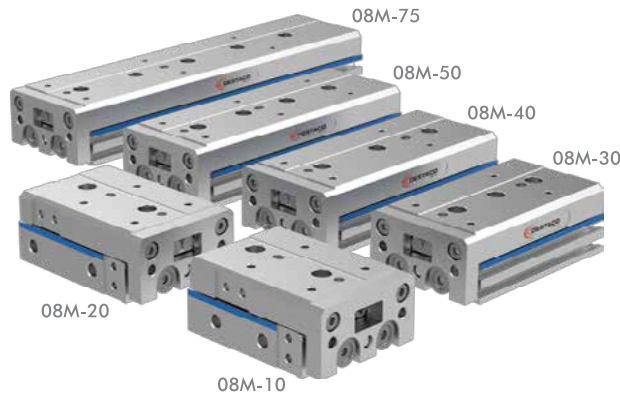

Specifications	Units	08M
Thrust Force at 7 bar [100 psi]	Retract	N [lbf]
	Extend	
Pressure Range	bar [psi]	1.5-7 [22-100]
Cylinder Bore Diameter [x2]	mm [in]	8 [0.31]
Speed Range	mm/sec [in/sec]	50-500 [2-20]
End Stop Repeatability, Basic Unit	mm [in]	±0.5 [±0.02]
End Stop Repeatability, Stop Kit	mm [in]	±0.2 [±0.01]
End Stop Repeatability, Shock Kit	mm [in]	±0.02 [±0.001]
Valve Required to Actuate		4 Way 2 Position

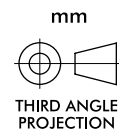
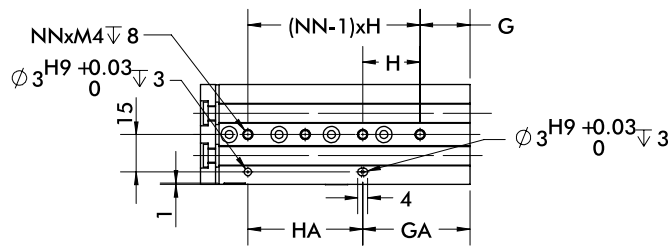
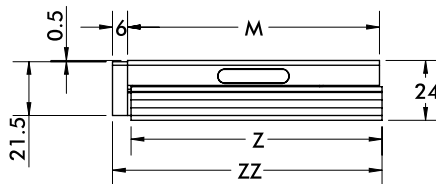
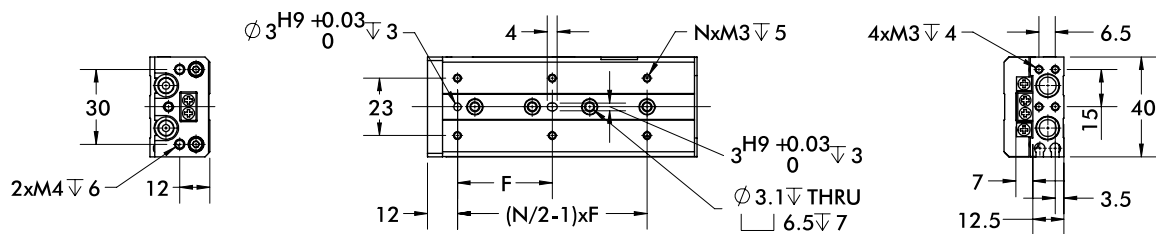
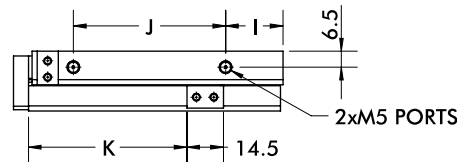

Stroke\Item	F	N	G	H	NN	GA	HA	I	J	K	M	Z	ZZ
10	25	4	9	28	2	17	20	12	20	23.5	49	48.5	56
20	25	4	12	30	2	12	30	7	30	33.5	54	53.5	61
30	40	4	13	20	3	33	20	7	41	43.5	65	64.5	72
40	50	4	15	28	3	43	28	10	56	53.5	83	82.5	90
50	38	6	20	23	4	43	46	23	61	63.5	101	100.5	108
75	50	6	27	28	5	83	56	40	94	88.5	151	150.5	158



GR-OEM-21

Dimensions and technical information are subject to change without notice

T110-08M

OEM Linear Slides | Technical Specifications

Specifications	Units	08M-10	08M-20	08M-30
Stroke	mm (in)	10 [0.39]	20 [0.79]	30 [1.18]
Weight	kg (lb)	0.15 [0.333]	0.16 [0.356]	0.19 [0.422]
Displacement	cc (cu-in)	1.01 [0.061]	2.01 [0.123]	3.02 [0.184]
Max. Applied Load	N (lbf)	10 [2.248]	10 [2.248]	10 [2.248]

Specifications	Units	08M-40	08M-50	08M-75
Stroke	mm (in)	40 [1.57]	50 [1.97]	75 [2.95]
Weight	kg (lb)	0.24 [0.522]	0.29 [0.633]	0.41 [0.911]
Displacement	cc (cu-in)	4.02 [0.245]	5.03 [0.307]	7.54 [0.460]
Max. Applied Load	N (lbf)	10 [2.248]	10 [2.248]	10 [2.248]

Deflection

(Note: Moment calculations located on page 31)

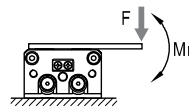
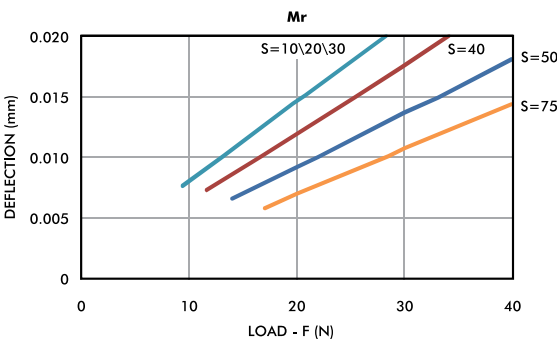
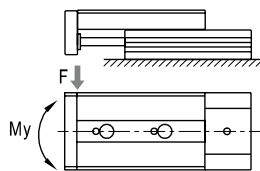
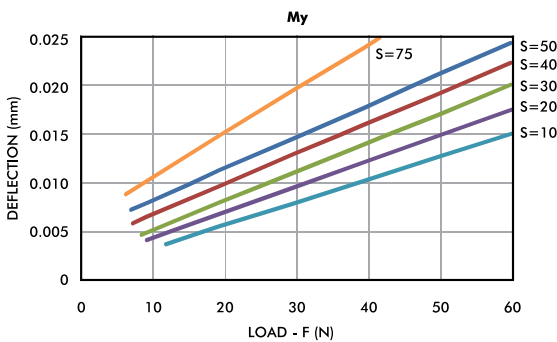
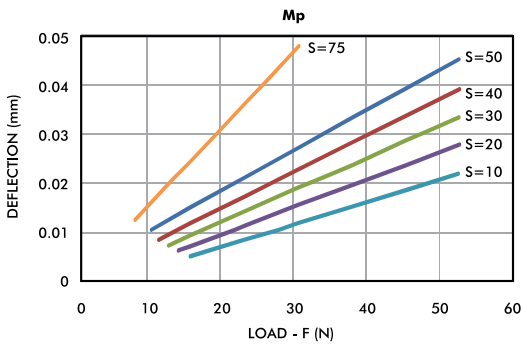

Payload vs. Velocity

TOP MOUNTING PAYLOAD vs. VELOCITY

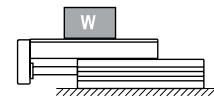
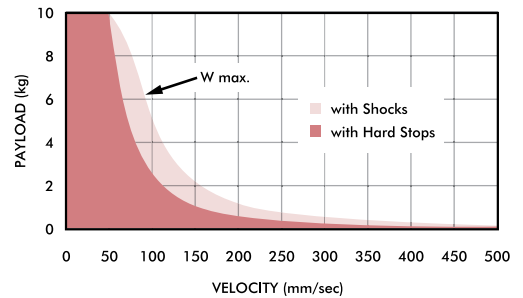

Top Mounting

FRONT MOUNTING PAYLOAD vs. VELOCITY

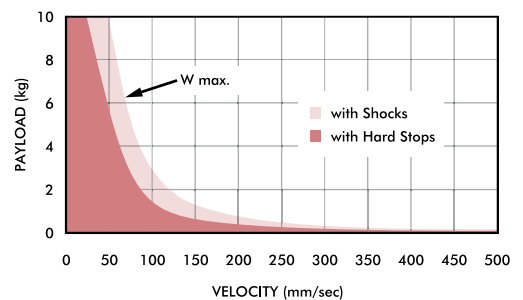

Front Mounting

T110-12M

OEM Linear Slide | Dimensions and Technical Specifications

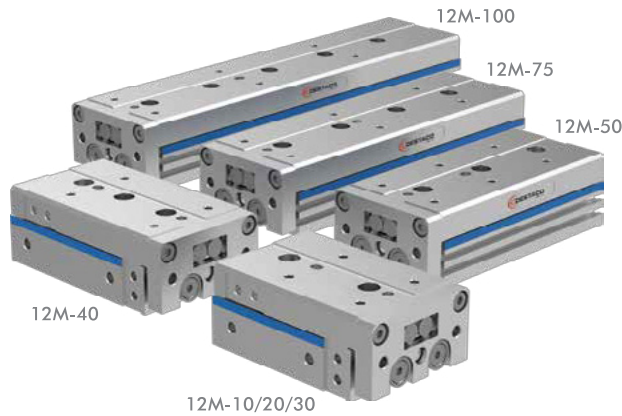

Specifications	Units	12M
Thrust Force at 7 bar [100 psi]	Retract	119 [26.8]
	Extend	158 [35.6]
Pressure Range	bar [psi]	1.5-7 [22-100]
Cylinder Bore Diameter [x2]	mm [in]	12 [0.47]
Speed Range	mm/sec [in/sec]	50-500 [2-20]
End Stop Repeatability, Basic Unit	mm [in]	±0.5 [±0.02]
End Stop Repeatability, Stop Kit	mm [in]	±0.2 [±0.01]
End Stop Repeatability, Shock Kit	mm [in]	±0.02 [±0.001]
Valve Required to Actuate		4 Way 2 Position

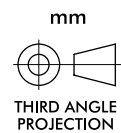
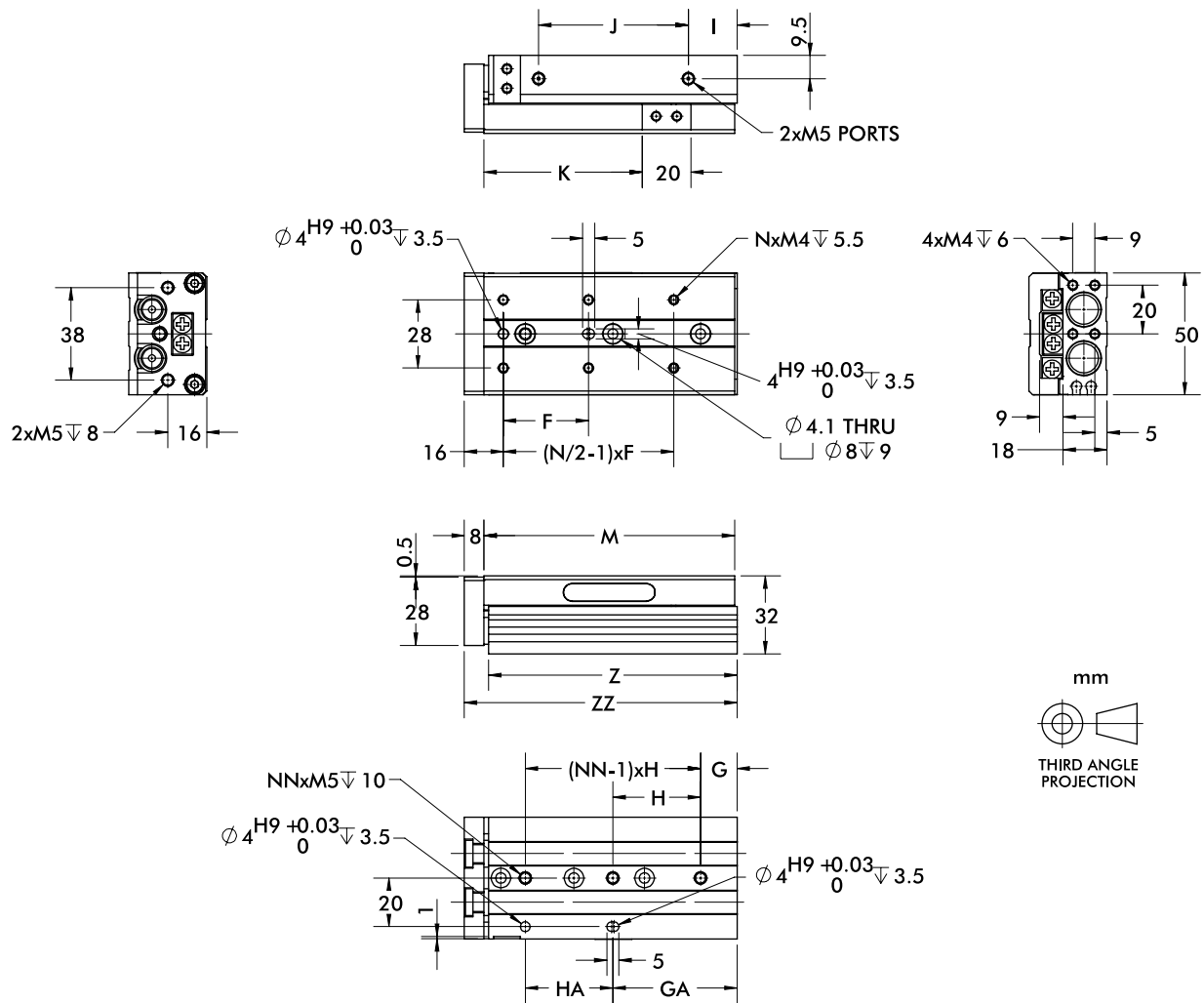

Stroke\Item	F	N	G	H	NN	GA	HA	I	J	K	M	Z	ZZ
10	35	4	15	40	2	15	40	10	39.5	25	71	70	80
20	35	4	15	40	2	15	40	10	39.5	35	71	70	80
30	35	4	15	40	2	15	40	10	39.5	45	71	70	80
40	50	4	17	25	3	42	25	10	51.5	55	83	82	92
50	35	6	15	36	3	51	36	20	61.5	65	103	102	112
75	55	6	25	36	4	61	72	40	87.5	90	149	148	158
100	65	6	35	38	5	111	76	50	131.5	115	203	202	212



GR-OEM-23

Dimensions and technical information are subject to change without notice

T110-12M

OEM Linear Slides | Technical Specifications

Specifications	Units	12M-10	12M-20	12M-30	12M-40
Stroke	mm (in)	10 [0.39]	20 [0.79]	30 [1.18]	40 [1.57]
Weight	kg (lb)	0.33 [0.722]	0.33 [0.722]	0.33 [0.722]	0.39 [0.856]
Displacement	cc (cu-in)	2.26 [0.138]	4.52 [0.276]	6.79 [0.414]	9.05 [0.552]
Max. Applied Load	N (lbf)	20 [4.496]	20 [4.496]	20 [4.496]	20 [4.496]

Specifications	Units	12M-50	12M-75	12M-100
Stroke	mm (in)	50 [1.97]	75 [2.95]	100 [3.94]
Weight	kg (lb)	0.48 [1.067]	0.66 [1.467]	0.89 [1.978]
Displacement	cc (cu-in)	11.31 [0.690]	16.97 [1.035]	22.62 [1.381]
Max. Applied Load	N (lbf)	20 [4.496]	20 [4.496]	20 [4.496]

Deflection

(Note: Moment calculations located on page 31)

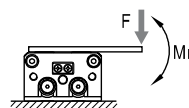
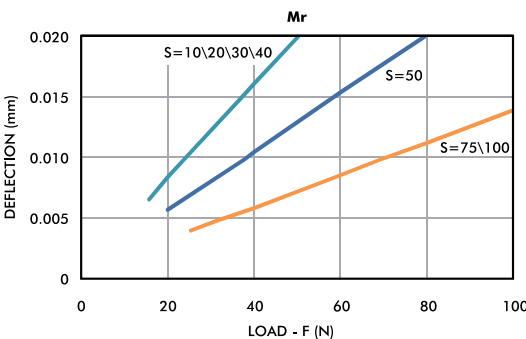
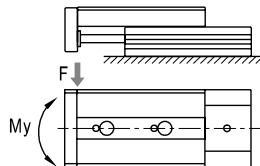
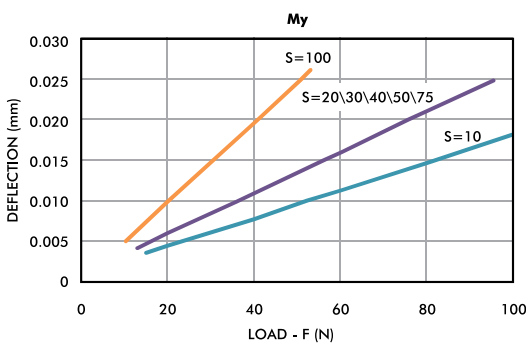
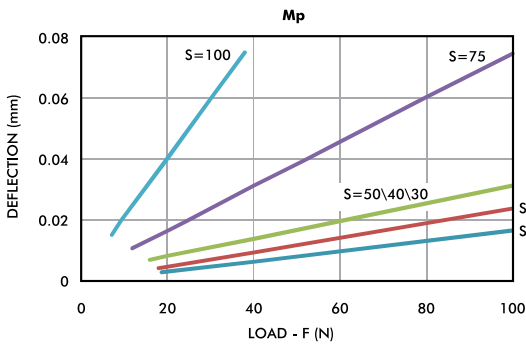

Payload vs. Velocity

TOP MOUNTING PAYLOAD vs. VELOCITY

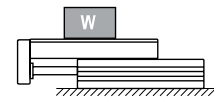
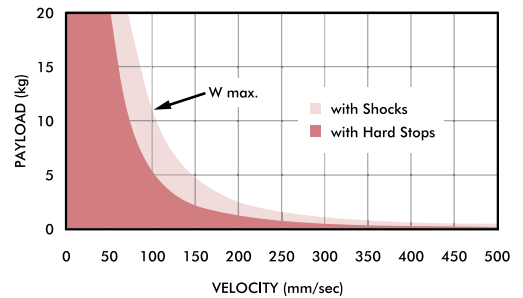

Top Mounting

FRONT MOUNTING PAYLOAD vs. VELOCITY

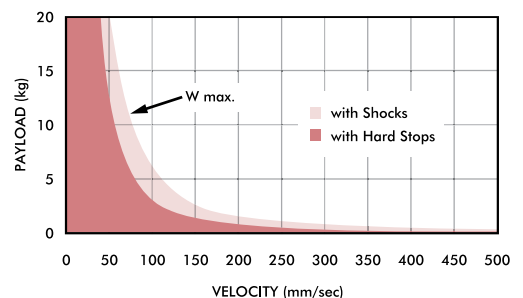

Front Mounting

T110-16M

OEM Linear Slide | Dimensions and Technical Specifications

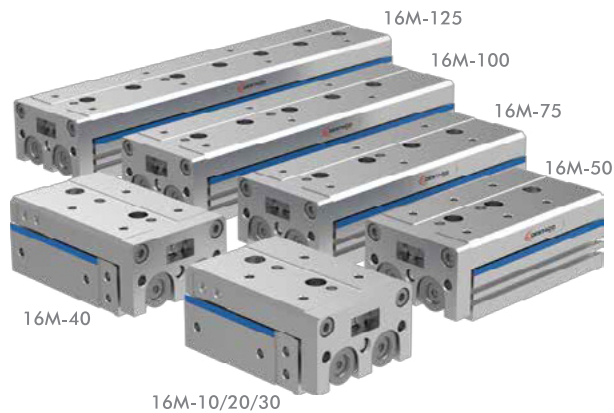

Specifications	Units	16M	
Thrust Force at 7 bar [100 psi]	Retract	N [lbf]	211 [47.4]
	Extend		281 [63.2]
Pressure Range	bar [psi]	1.5-7 [22-100]	
Cylinder Bore Diameter [x2]	mm [in]	16 [0.63]	
Speed Range	mm/sec [in/sec]	50-500 [2-20]	
End Stop Repeatability, Basic Unit	mm [in]	±0.5 [±0.02]	
End Stop Repeatability, Stop Kit	mm [in]	±0.2 [±0.01]	
End Stop Repeatability, Shock Kit	mm [in]	±0.02 [±0.001]	
Valve Required to Actuate		4 Way 2 Position	

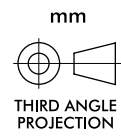
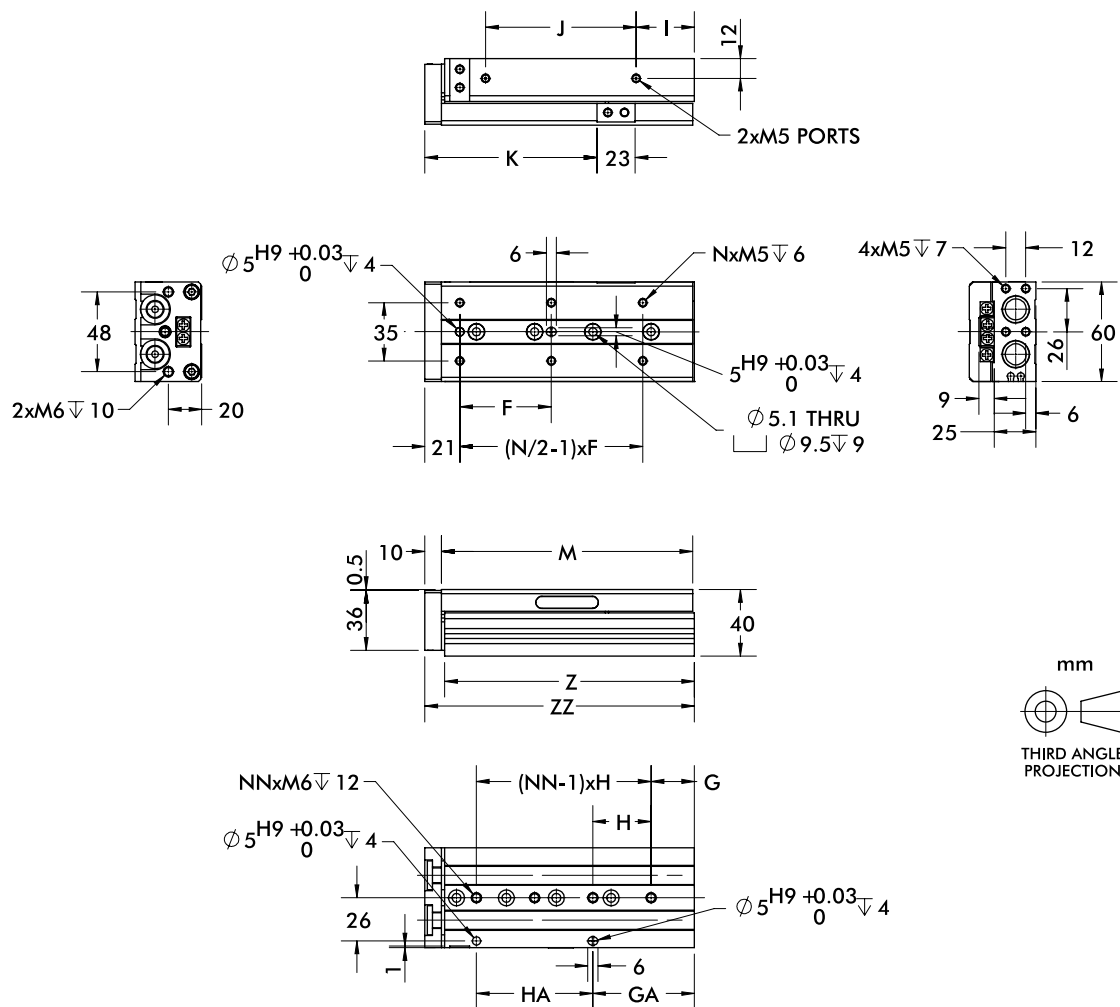

Stroke\Item	F	N	G	H	NN	GA	HA	I	J	K	M	Z	ZZ
10	35	4	16	40	2	16	40	8	42.5	28.5	76	75	87
20	35	4	16	40	2	16	40	8	42.5	38.5	76	75	87
30	35	4	16	40	2	16	40	8	42.5	48.5	76	75	87
40	40	4	16	50	2	16	50	8	52.5	58.5	86	85	97
50	30	6	21	30	3	51	30	12	63.5	68.5	101	100	112
75	55	6	26	35	4	61	70	35	90.5	93.5	151	150	162
100	65	6	39	35	5	109	70	55	118.5	118.8	199	198	210
125	70	8	19	35	7	159	70	70	153.5	143.5	249	248	260



GR-OEM-25

Dimensions and technical information are subject to change without notice

T110-16M

OEM Linear Slides | Technical Specifications

Specifications	Units	16M-10	16M-20	16M-30	16M-40
Stroke	mm (in)	10 [0.39]	20 [0.79]	30 [1.18]	40 [1.57]
Weight	kg (lb)	0.57 [1.267]	0.57 [1.267]	0.58 [1.289]	0.64 [1.422]
Displacement	cc (cu-in)	4.02 [0.245]	8.04 [0.491]	12.07 [0.736]	16.09 [0.982]
Max. Applied Load	N (lbf)	35 [7.868]	35 [7.868]	35 [7.868]	35 [7.868]

Specifications	Units	16M-50	16M-75	16M-100	16M-125
Stroke	mm (in)	50 [1.97]	75 [2.95]	100 [3.94]	125 [4.92]
Weight	kg (lb)	0.76 [1.689]	1.09 [2.422]	1.37 [3.044]	1.70 [3.778]
Displacement	cc (cu-in)	20.11 [1.227]	30.16 [1.841]	40.22 [2.454]	50.27 [3.068]
Max. Applied Load	N (lbf)	35 [7.868]	35 [7.868]	35 [7.868]	35 [7.868]

Deflection

(Note: Moment calculations located on page 31)

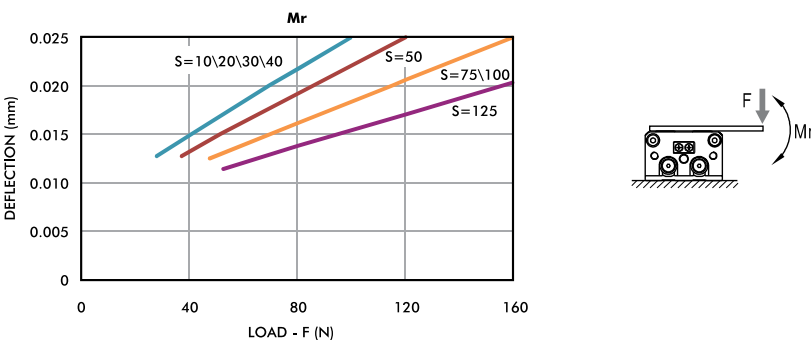
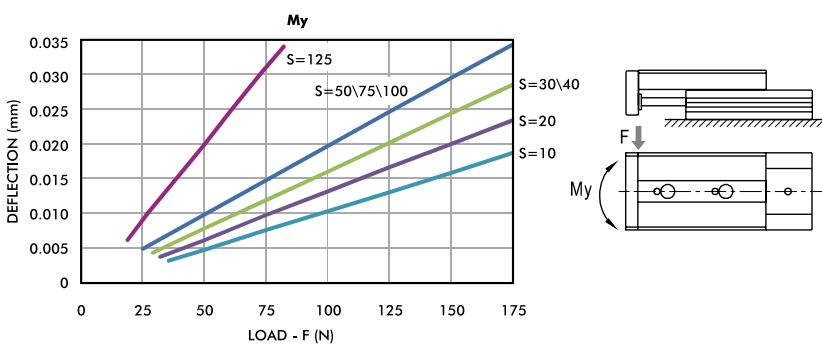
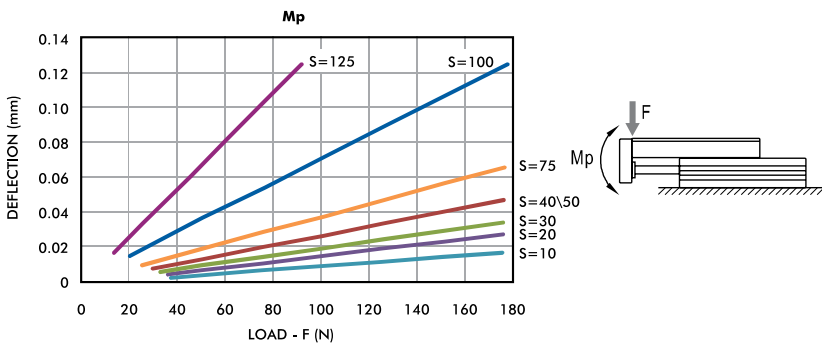

Payload vs. Velocity

TOP MOUNTING PAYLOAD vs. VELOCITY

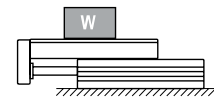
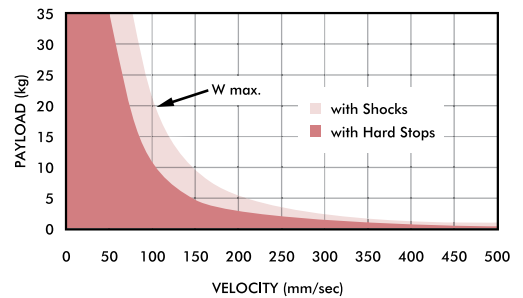

Top Mounting

FRONT MOUNTING PAYLOAD vs. VELOCITY

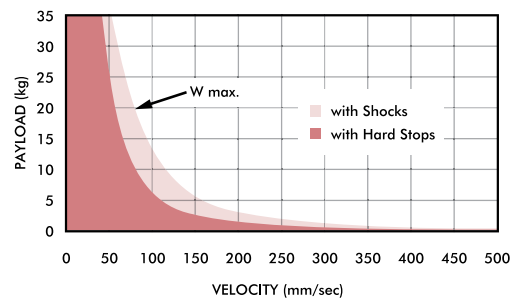

Front Mounting

T110-20M

OEM Linear Slide | Dimensions and Technical Specifications

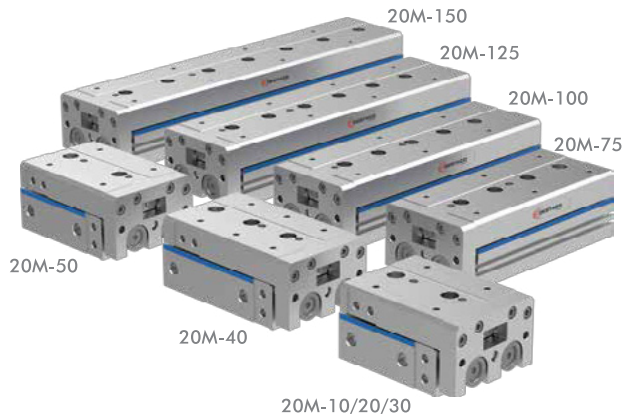

Specifications	Units	20M	
Thrust Force at 7 bar [100 psi]	Retract	N [lbf]	330 [74.2]
	Extend		440 [99.0]
Pressure Range	bar [psi]	1.5-7 [22-100]	
Cylinder Bore Diameter [x2]	mm [in]	20 [0.78]	
Speed Range	mm/sec [in/sec]	50-500 [2-20]	
End Stop Repeatability, Basic Unit	mm [in]	±0.5 [±0.02]	
End Stop Repeatability, Stop Kit	mm [in]	±0.2 [±0.01]	
End Stop Repeatability, Shock Kit	mm [in]	±0.02 [±0.001]	
Valve Required to Actuate		4 Way 2 Position	

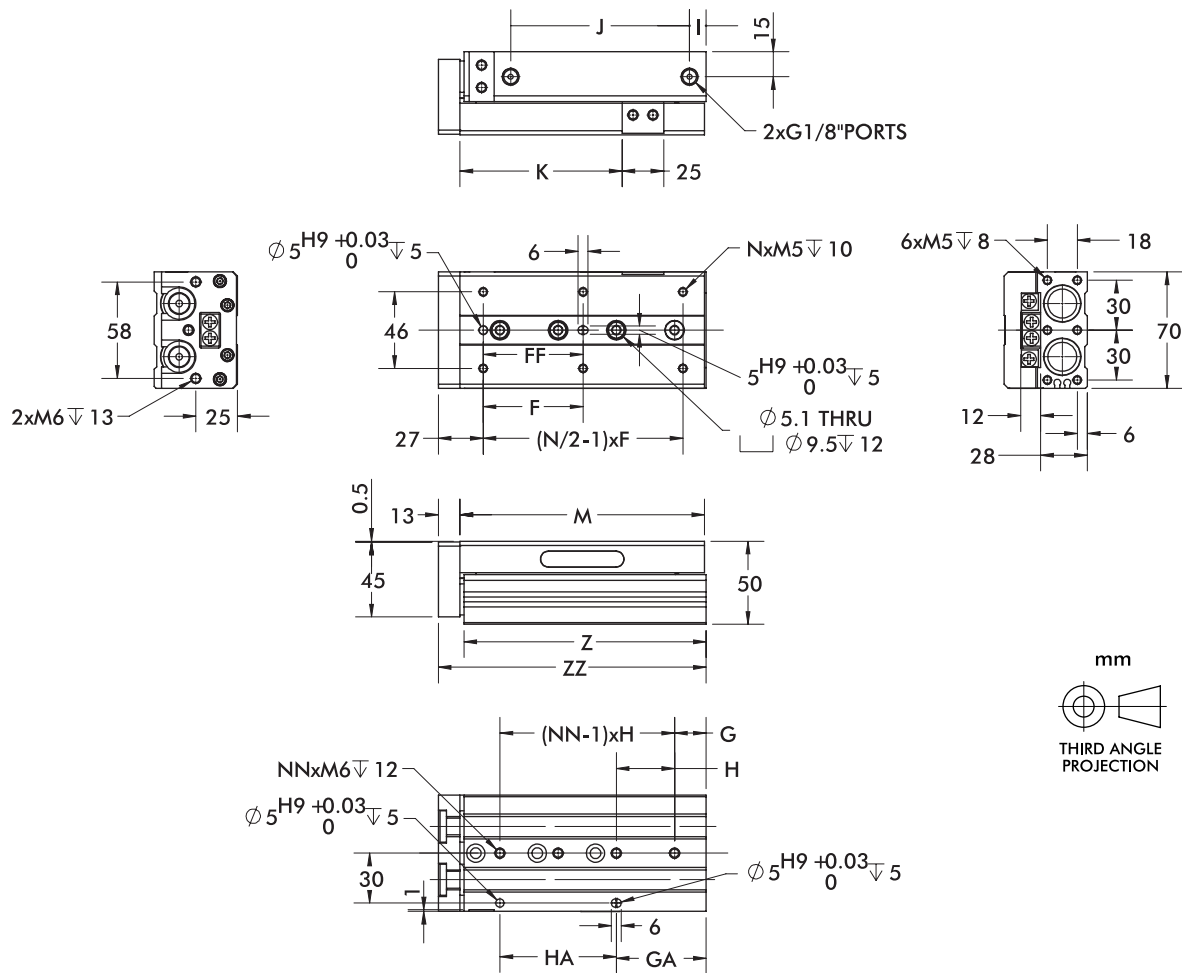

Stroke\Item	F	FF	N	G	H	NN	GA	HA	I	J	K	M	Z	ZZ
10	50	40	4	15	45	2	25	35	10	43.5	32.5	83	81.5	97
20	50	40	4	15	45	2	25	35	10	43.5	42.5	83	81.5	97
30	50	40	4	15	45	2	25	35	10	43.5	52.5	83	81.5	97
40	60	50	4	15	55	2	35	35	10	53.5	62.5	93	91.5	107
50	35	35	6	15	35	3	50	35	10	68.5	72.5	108	106.5	122
75	60	60	6	19	35	4	54	70	10	107.5	97.5	147	145.5	161
100	70	70	6	37	35	5	107	70	55	115.5	122.5	200	198.5	214
125	70	70	8	41	38	6	155	76	70	154.5	147.5	254	252.5	268
150	80	80	8	19	44	7	195	88	90	186.5	172.5	306	304.5	320



GR-OEM-27

Dimensions and technical information are subject to change without notice

T110-20M

OEM Linear Slides | Technical Specifications

Specifications	Units	20M-10	20M-20	20M-30	20M-40	20M-50
Stroke	mm (in)	10 [0.39]	20 [0.79]	30 [1.18]	40 [1.57]	50 [1.97]
Weight	kg (lb)	0.96 [2.133]	0.98 [2.178]	1.01 [2.244]	1.10 [2.44]	1.25 [2.778]
Displacement	cc (cu-in)	6.28 [0.383]	12.57 [0.767]	18.85 [1.150]	25.14 [1.534]	31.42 [1.917]
Max. Applied Load	N (lbf)	55 [12.364]	55 [12.364]	55 [12.364]	55 [12.364]	55 [12.364]

Specifications	Units	20M-75	20M-100	20M-125	20M-150
Stroke	mm (in)	75 [2.95]	100 [3.94]	125 [4.92]	150 [5.91]
Weight	kg (lb)	1.63 [3.622]	2.15 [4.778]	2.67 [5.933]	3.19 [7.089]
Displacement	cc (cu-in)	47.13 [2.876]	62.84 [3.838]	78.55 [4.793]	94.26 [5.752]
Max. Applied Load	N (lbf)	55 [12.364]	55 [12.364]	55 [12.364]	55 [12.364]

Deflection

(Note: Moment calculations located on page 31)

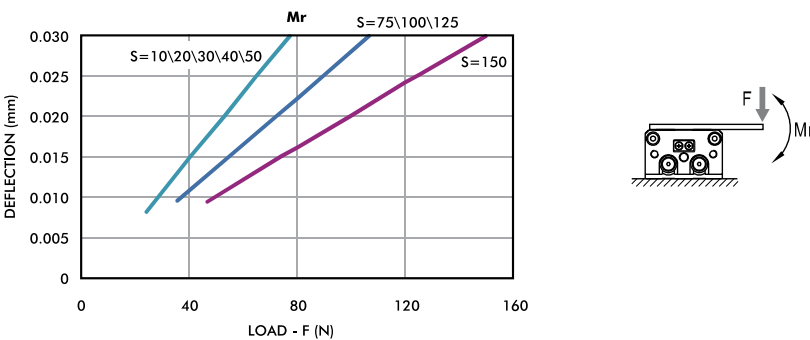
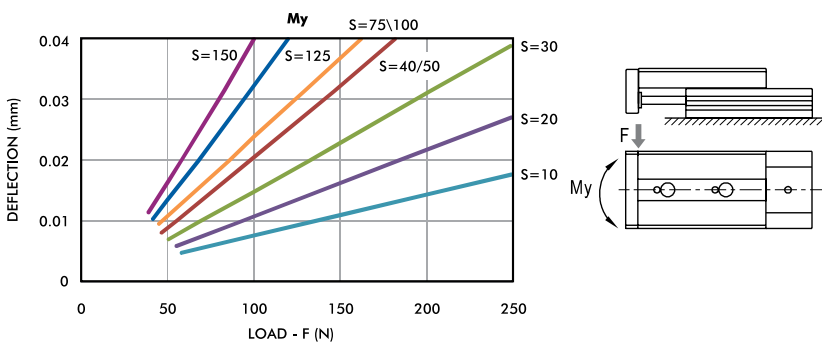
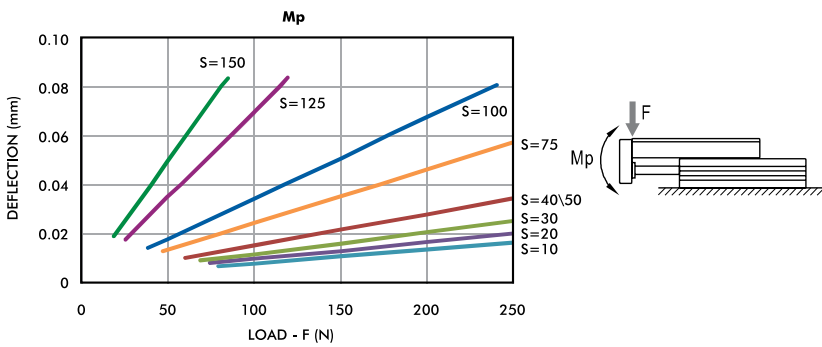

Payload vs. Velocity

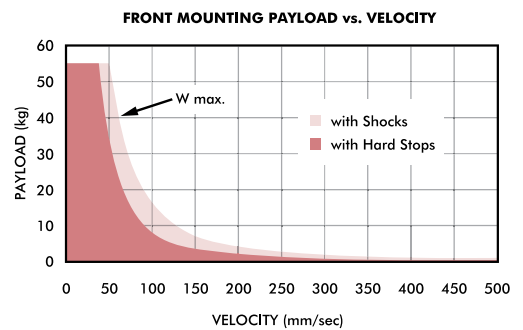
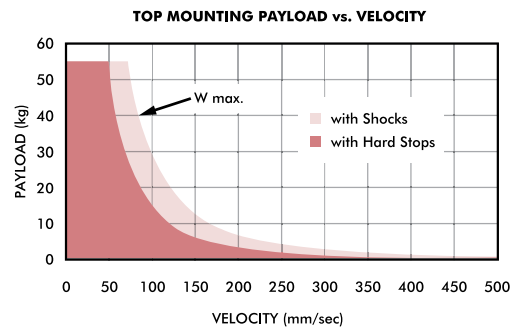

T110-25M

OEM Linear Slide | Dimensions and Technical Specifications

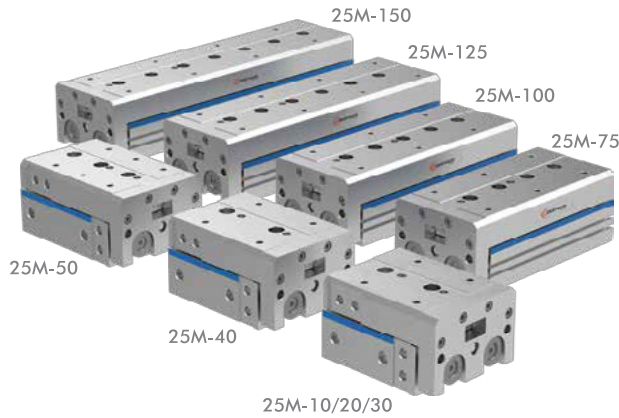

Specifications	Units	25M	
Thrust Force at 7 bar [100 psi]	Retract	N [lbf]	529 [119.0]
	Extend		687 [154.5]
Pressure Range	bar [psi]	1.5-7 [22-100]	
Cylinder Bore Diameter [x2]	mm [in]	25 [0.98]	
Speed Range	mm/sec [in/sec]	50-500 [2-20]	
End Stop Repeatability, Basic Unit	mm [in]	±0.5 [±0.02]	
End Stop Repeatability, Stop Kit	mm [in]	±0.2 [±0.01]	
End Stop Repeatability, Shock Kit	mm [in]	±0.02 [±0.001]	
Valve Required to Actuate		4 Way 2 Position	

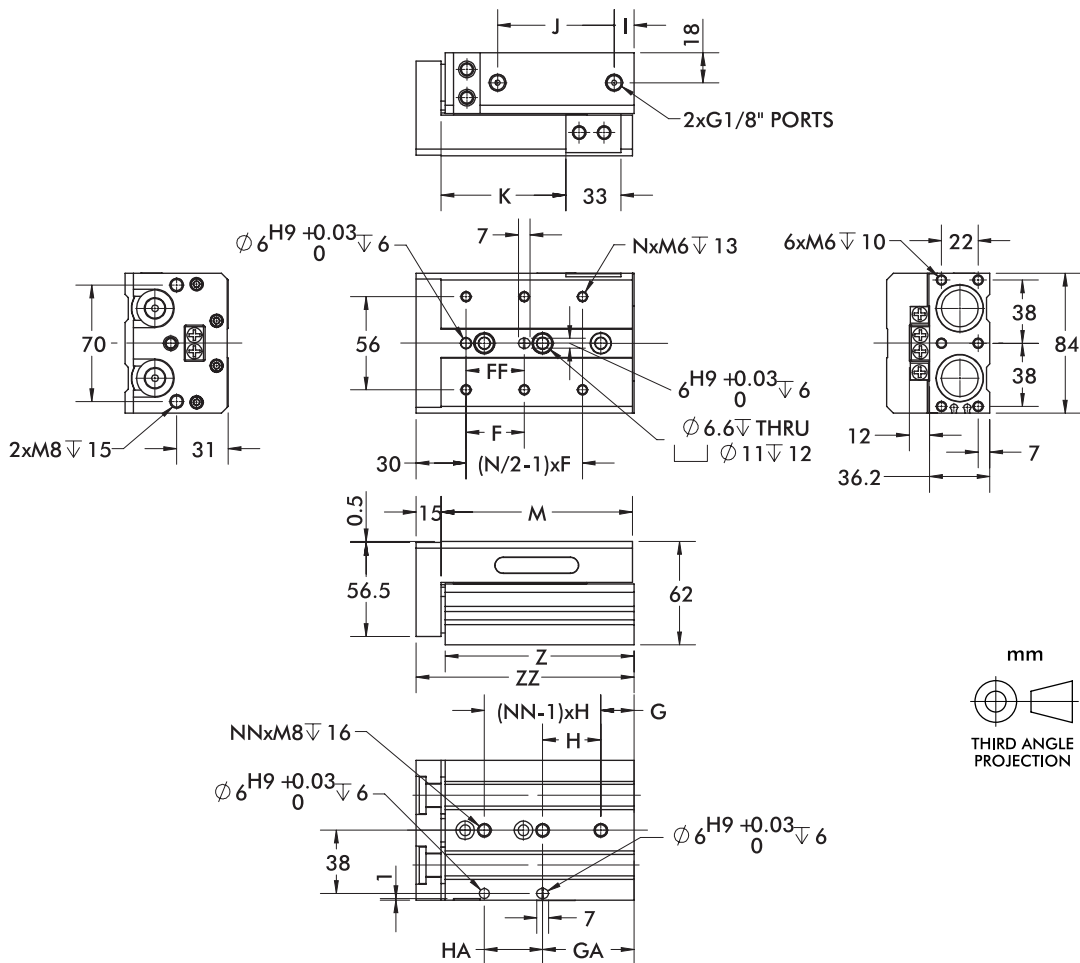

Stroke\Item	F	FF	N	G	H	NN	GA	HA	I	J	K	M	Z	ZZ
10	50	40	4	22	45	2	22	45	12	47	35	92	90.5	108
20	50	40	4	22	45	2	22	45	12	47	45	92	90.5	108
30	50	40	4	22	45	2	22	45	12	47	55	92	90.5	108
40	60	50	4	22	55	2	22	55	12	57	65	102	100.5	118
50	35	35	6	20	35	3	55	35	12	70	75	115	113.5	131
75	60	60	6	26	35	4	61	70	33	90	100	156	154.5	172
100	70	70	6	32	35	5	102	70	45	119	125	197	195.5	213
125	75	75	8	40	38	6	154	76	67	155	150	255	253.5	271
150	80	80	8	30	40	7	190	80	82	180	175	295	293.5	311



GR-OEM-29

Dimensions and technical information are subject to change without notice

T110-25M

OEM Linear Slides | Technical Specifications

Specifications	Units	25M-10	25M-20	25M-30	25M-40	25M-50
Stroke	mm (in)	10 [0.39]	20 [0.79]	30 [1.18]	40 [1.57]	50 [1.97]
Weight	kg (lb)	1.66 [3.689]	1.68 [3.733]	1.69 [3.756]	1.84 [4.089]	2.09 [4.644]
Displacement	cc (cu-in)	9.82 [0.599]	19.64 [1.198]	29.46 [1.798]	39.28 [2.397]	49.09 [2.996]
Max. Applied Load	N (lbf)	70 [15.737]	70 [15.737]	70 [15.737]	70 [15.737]	70 [15.737]

Specifications	Units	25M-75	25M-100	25M-125	25M-150
Stroke	mm (in)	75 [2.95]	100 [3.94]	125 [4.92]	150 [5.91]
Weight	kg (lb)	2.65 [5.889]	3.27 [7.267]	4.14 [9.1]	4.71 [10.467]
Displacement	cc (cu-in)	73.645 [4.494]	98.19 [5.992]	122.73 [7.490]	147.28 [8.922]
Max. Applied Load	N (lbf)	70 [15.737]	70 [15.737]	70 [15.737]	70 [15.737]

Deflection

(Note: Moment calculations located on page 31)

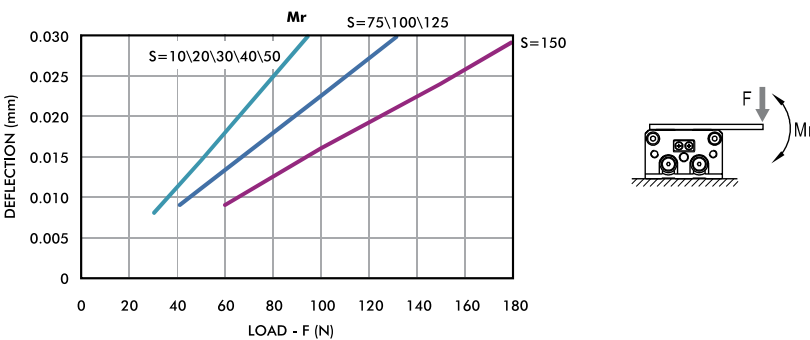
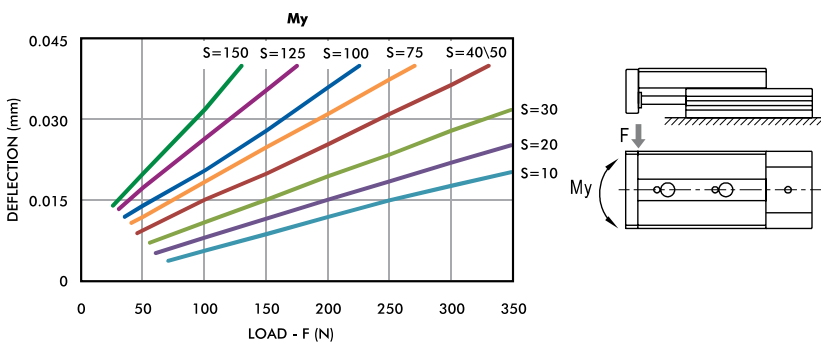
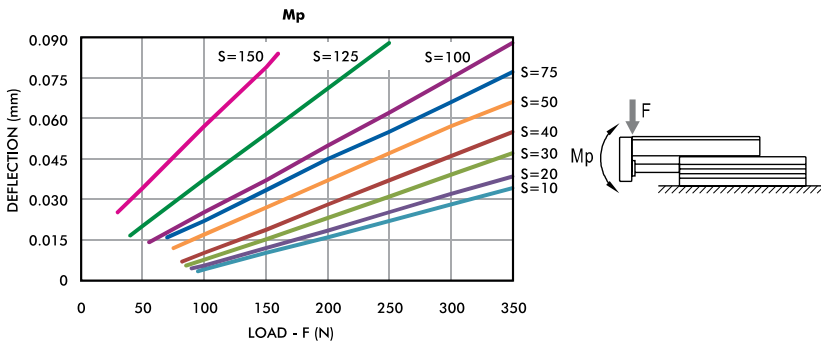

Payload vs. Velocity

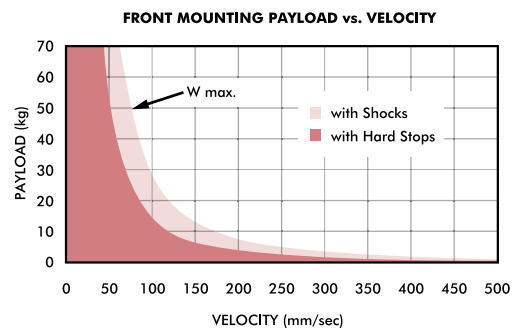
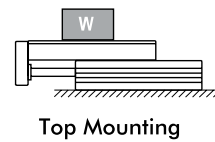
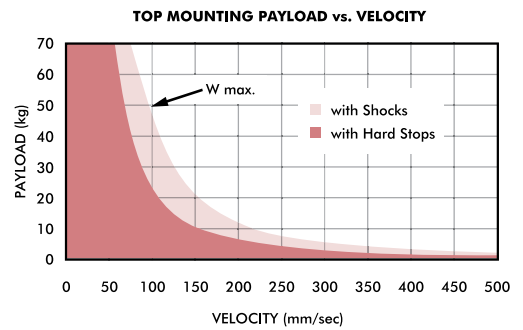

T100 SERIES

OEM Linear Slide | Offset Loading Formula

	Horizontal Mounting	Side Mounting	Vertical Mounting
Pitch 	Static Moment: $M_p = \frac{W \times (L1+A)}{1000}$ Dynamic Moment: $M_{po} = \frac{W \times (L1+A)}{1000} + \frac{W \times a \times (L2+B)}{1000 \times g}$	Static Moment: $M_p = 0$ Dynamic Moment: $M_{po} = \frac{W \times a \times (L2+B)}{1000 \times g}$	Static Moment: $M_p = \frac{W \times (L2+B)}{1000}$ Dynamic Moment: $M_{po} = \frac{W \times (L2+B)}{1000} + \frac{W \times a \times (L2+B)}{1000 \times g}$
Roll 	Static Moment: $M_r = \frac{W \times (C+L3)}{1000}$ Dynamic Moment: $M_{ro} = \text{Static Moment}$	Static Moment: $M_r = \frac{W \times (B+L2)}{1000}$ Dynamic Moment: $M_{ro} = \text{Static Moment}$	Static Moment: $M_r = 0$ Dynamic Moment: $M_{ro} = 0$
Yaw 	Static Moment: $M_y = 0$ Dynamic Moment: $M_{yo} = \frac{W \times a \times (C+L3)}{1000 \times g}$	Static Moment: $M_y = \frac{W \times (A+L1)}{1000}$ Dynamic Moment: $M_{yo} = \frac{W \times a \times (C+L3)}{1000 \times g} + \frac{W \times (A+L1)}{1000}$	Static Moment: $M_y = \frac{W \times (C+L3)}{1000}$ Dynamic Moment: $M_{yo} = \frac{W \times a \times (C+L3)}{1000 \times g} + \frac{W \times (C+L3)}{1000}$

Instructions:

1. Select mounting configuration, Horizontal, Side or Vertical
2. Define position of payload center of gravity L1, L2 & L3. A, B & C can be found in table 2
3. Calculate both static and dynamic moments for pitch, roll and yaw for your mounting configuration
4. Calculate combined moments with respect to max allowable (table 2). Must be less than or equal to 1.

$$\text{Static } \frac{M_p}{M_{p_{max}}} + \frac{M_y}{M_{y_{max}}} + \frac{M_r}{M_{r_{max}}} \leq 1$$

$$\text{Dynamic } \frac{M_{po}}{M_{po_{max}}} + \frac{M_{yo}}{M_{yo_{max}}} + \frac{M_{ro}}{M_{ro_{max}}} \leq 1$$

Table 1. Symbol and Unit of Measure

Symbol	Item	Unit
A, B, C	Correction value for center position distance of moment (See Table 2)	mm
a	Acceleration due to inertia (See below)	m/s ²
g	Acceleration due to gravity g=9.81	m/s ²
L1, L2, L3	Overhang (customer supplied)	mm
Mp, My, Mr	Static moment (Pitch, Yaw, Roll)	Nm
Mp _{max} , My _{max} , Mr _{max}	Maximum allowable static moment (Pitch, Yaw, Roll. See Table 2)	Nm
Mpo, Myo, Mro	Dynamic moment (Pitch, Yaw, Roll)	Nm
Mpo _{max} , Myo _{max} , Mro _{max}	Maximum allowable dynamic moment (Pitch, Yaw, Roll. See Table 2)	Nm
Va	Average speed (customer supplied)	mm/s
W	Payload (customer supplied)	N

Acceleration due to inertia: Bumper: $a = 1600 \times (Va/1000)^2$ Shock Absorber: $a = 400 \times (Va/1000)^2$



GR-OEM-31

Dimensions and technical information are subject to change without notice

T100 SERIES

Table 2. Maximum Allowable Moments

Bore Size	Stroke (mm)	Dynamic Moment (Nm)			Static Moment (Nm)			Correction Value (mm)		
		M _{po} _{max}	M _{yo} _{max}	M _{ro} _{max}	M _p _{max}	M _y _{max}	M _r _{max}	A	B	C
06M	10	3.3	3.8	2.6	0.7	0.7	0.6	27	7.3	16
	20	3.3	3.8	2.6	0.7	0.8	0.6	42		
	30	3.3	3.8	2.6	0.7	0.8	0.6	52		
	40	7.2	7.9	3.6	1.3	1.3	0.6	72		
	50	12.4	12.7	4.7	1.8	1.8	0.6	87		
08M	10	10.1	9.1	8.8	2.5	2.5	2	32	8.5	20
	20	10.1	9.1	8.8	2.6	2.6	2	42		
	30	10.1	9.1	8.8	2.8	2.8	2	57		
	40	12.4	10.8	10.1	3.4	3.4	2.3	72		
	50	23.6	24.8	13.9	4.4	4.4	2.1	92		
	75	32.8	35.3	16.4	4.6	4.6	1.8	132		
12M	10	33	34.3	30.9	7.3	7.3	5.8	48	10	25
	20	33	34.3	30.9	7.6	7.6	5.8	58		
	30	33	34.3	30.9	7.8	7.8	5.8	68		
	40	33	34.3	30.9	8	8	5.8	78		
	50	53.4	49.6	39.7	9.8	9.8	5.8	88		
	75	78.8	71.9	48.6	14.2	14.2	6.8	125		
	100	78.8	71.9	48.6	14.7	14.7	6.8	160		
16M	10	33	34.3	30.9	8.8	8.8	7.6	43	11	30
	20	33	34.3	30.9	9.2	9.2	7.6	53		
	30	33	34.3	30.9	9.5	9.5	7.6	63		
	40	33	34.3	30.9	10	10	7.6	78		
	50	53.4	49.6	39.7	12.2	12.2	7.6	93		
	75	78.8	71.9	48.6	17.6	17.6	8.9	130		
	100	78.8	71.9	48.6	18.2	18.2	8.9	165		
	125	143.7	144.5	53.3	24.8	24.8	7.8	204		
20M	10	60.1	50.5	72.8	14.5	14.5	15.2	47	16.5	35
	20	60.1	50.5	72.8	15.2	15.2	15.2	57		
	30	60.1	50.5	72.8	15.7	15.7	15.2	67		
	40	60.1	50.5	72.8	16.3	16.3	15.2	82		
	50	60.1	50.5	72.8	16.6	16.6	15.2	92		
	75	169.3	154.3	114.4	41.2	41.2	22	136		
	100	169.3	154.3	114.4	42.8	42.8	22	176		
	125	169.3	154.3	114.4	43.6	43.6	22	205		
	150	267.5	286.6	145.6	49	49	20.5	249		
25M	10	60.1	50.5	72.8	16.3	16.3	17.6	52	20.3	42
	20	60.1	50.5	72.8	17	17	17.6	62		
	30	60.1	50.5	72.8	17.4	17.4	17.6	72		
	40	60.1	50.5	72.8	17.8	17.8	17.6	82		
	50	60.1	50.5	72.8	18.2	18.2	17.6	96		
	75	169.3	154.3	114.4	45.2	45.2	25.3	141		
	100	169.3	154.3	114.4	46.2	46.2	25.3	165		
	125	169.3	154.3	114.4	48	48	25.3	210		
	150	267.5	286.6	145.6	65	65	28.3	254		





Dimensions and technical information are subject to change without notice

GR-OEM-32



LINEAR SLIDES

Linear Slides | Product Overview | DIRECTCONNECT™ Mounting

Model	Stroke mm [in]	Thrust Force N [lbs]	Operating Environment	Special Features	Page GR-LIN-#
DLB 	6-500 [0.25-26]	89-560 [20-126]	IP54	High Reliability with smooth operation base slide. Internal or external air cylinder options. DIRECTCONNECT.	3
DLT 	6-700 [0.25-28]	89-560 [20-126]	IP54	High Reliability with smooth operation Thrust slide. Internal or external air cylinder options. DIRECTCONNECT.	17
DLM 	5-100 [0.2-4]	67-230 [15-52]	IP54	Precise positioning with stroke adjustments. High load and moment capacity. DIRECTCONNECT.	37
MPS 	13-51 [0.5-2]	67-196 [15-44]	IP54	Compact slide with zero side play. Dual-V bearing design. Adjustable stops.	43

DIRECTCONNECT. Modular Direct Mounting System without Adapter Plates

Products can be mounted in multiple positions. Refer to datasheet for complete info.

Slide to Slide

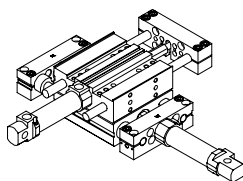

DLB Base Slide to DLT Thruster Slide

Slide to Slide

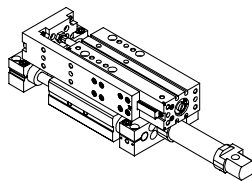

DLB Base Slide to DLM Thruster Slide

Slide to Gripper

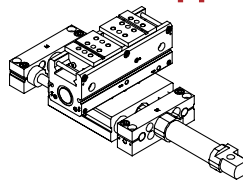

DLB Base Slide to DPG Parallel Gripper

Slide to Rotary

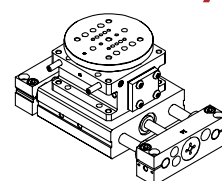

DLB Base Slide to DRF Rotary Actuator

Slide to Slide

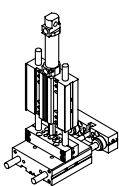

DLT Thruster Slide to DLT Thruster Slide

Slide to Slide

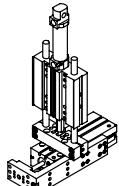

DLT Thruster Slide to DLM Thruster Slide

Slide to Gripper

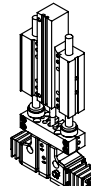

DLT Thruster Slide to DPDL Parallel Gripper

Slide to Rotary

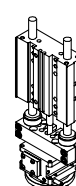

DLT Thruster Slide to DRF Rotary Actuator

Slide to Slide

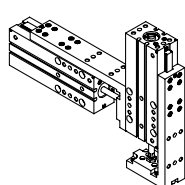

DLM Thruster Slide to DLM Thruster Slide

Slide to Slide

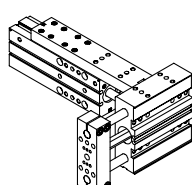

DLM Thruster Slide to DLT Thruster Slide

Slide to Gripper

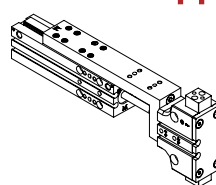

DLM Thruster Slide to DPDL Parallel Gripper

Slide to Rotary

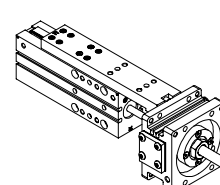

DLM Thruster Slide to DRG Rotary Actuator



GR-LIN-1

Dimensions and technical information are subject to change without notice

LINEAR SLIDES

Linear Slides | DIRECTCONNECT™ Mounting Compatibility Chart

DESTACO's DIRECTCONNECT™ technology, allows all components of the system—grippers, rotaries and slides—to be mounted together directly. Look for matching icons on product datasheets for mounting compatibility.

Note: The numbers in the cell represent the metric screw size and basic mounting pattern.

S=Square, R=Rectangle. ie; 5S = M5 Screw with square mounting pattern.

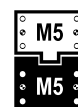

5S

5R

Catalog Models		Base Slides			Thruster Slides				
		DLB-06&08	DLB-10,12,16	DLB-20&25	DLT-06&08	DLT-10,12,16	DLT-20&25	DLM-07	DLM-09&12
Base Slides	DLB-06,08				3R,3S			3R,3S	
	DLB-10,12,16				3S	5R,5S		3S	5R,5S
	DLB-20,25					5S	10R,10S		5S
Thruster Slides	DLT-06,08	3R,3S	3S		3R	3R		3R	3R
	DLT-10,12,16		5R,5S	5S		5R	5R		5R
	DLT-20,25			10R,10S			10R		
	DLM-07	3R,3S	3S		3R	3R		3R	3R
	DLM-9,12		5R,5S	5S		5R	5R		5R
Rotary Actuators	DRF-075,094		5R			5R	5R		5R
	DRF-106		5R	10R		5R	10R		5R
	DRF-131		5R	10R		5R	10R		5R
	DRG-074,094		5R			5R	5R		5R
	DRG-106		5R	10R		5R	10R		5R
	DRG-131		5R	10R		5R	10R		5R
Grippers	DGC		5R			5R	5R		5R
	DPG		5R			5R	5R		5R
	DCT-12, 16,25	3R			3R	3R		3R	3R
	DCT-25		5R			5R	5R		5R
	DPDL-047,056	3R			3R	3R		3R	3R
	DPDL-088,125		5R			5R	5R		5R
	DPDL-175,250			10R			10R		
	DPDS-047,056	3R			3R	3R		3R	3R
	DPDS-088,125		5R			5R	5R		5R
	DPDS-175,250			10R			10R		
	DPL-25xx		5R			5R	5R		5R
	DPL-32xx,40xx			10R			10R		
	DPP-10,14	3R			3R	3R		3R	3R
	DPP-20		5R			5R	5R		5R
	DPP-28		5R	10R		5R	10R		5R
	DPW-250	3R			3R	3R		3R	3R
	DPW-375,500		5R			5R	5R		5R
	G100-08,011	3R			3R	3R		3R	3R
	G100-18,25		5R			5R	5R		5R
	DPE-200		5R			5R	5R		5R
DPE-400			10R			10R			

Dimensions and technical information are subject to change without notice

GR-LIN-2



BASE SLIDE ACCESSORIES

Linear Slides | Accessory Mounting Technical Data

DLB-B, L Internally Powered Base Slides

Shock Absorbers

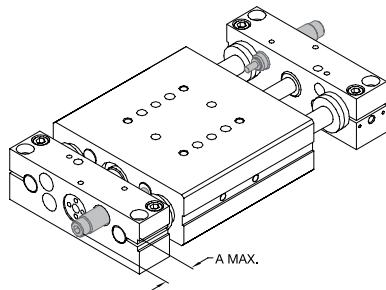

Adjustable Hard Stops

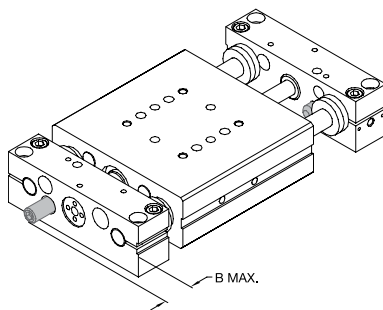

Inductive Proximity Sensors

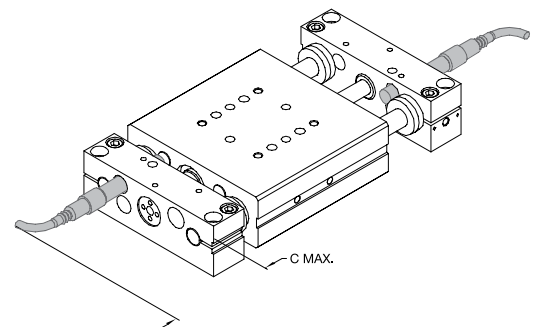

Telescopic Airlines

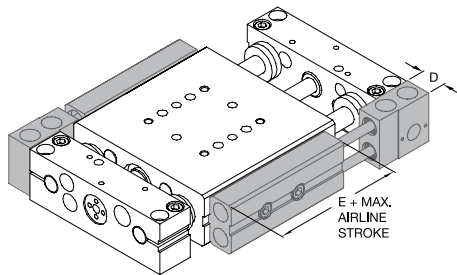

Flow Controls

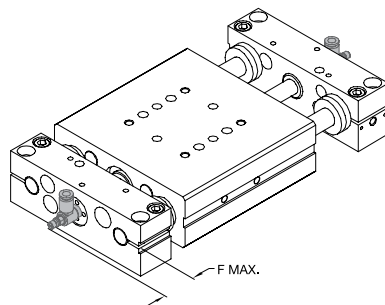

Model	A	B	C	D	E	F
DLB-06M	13.5 [0.53]	10.2 [0.40]	45.7 [1.8]	--	--	25.9 [1.02]
DLB-08M				--	--	
DLB-10M	17.8 [0.70]	11.9 [0.47]	63.5 [2.5]	14.7 [0.577]	91.4 [3.60]	31.8 [1.25]
DLB-12M	24.1 [0.95]					
DLB-16M						
DLB-20M	51.6 [2.03]	2.5 [0.10]	53.8 [2.1]			
DLB-25M	46.2 [1.82]		48.3 [1.9]			

Dimensions in mm [in]

DLB-T, A, R, U Externally Powered Base Slides

Shock Absorbers

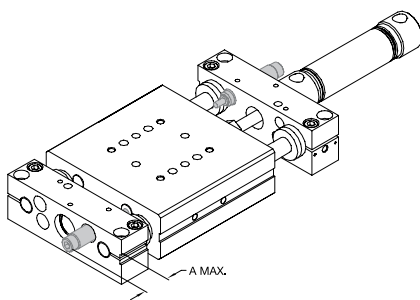

Adjustable Hard Stops

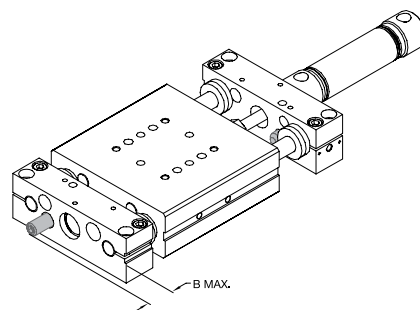

Telescoping Airlines & Flow Controls

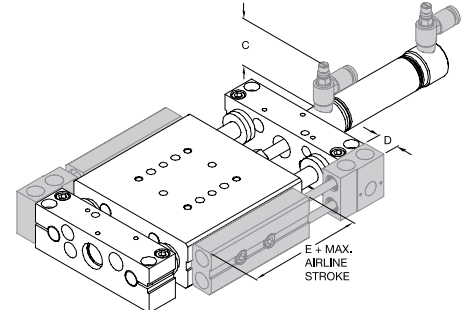

Inductive Proximity Sensors

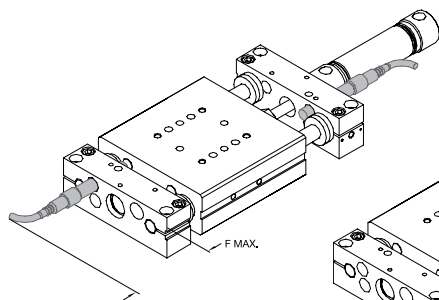

Magneto Resistive Sensors

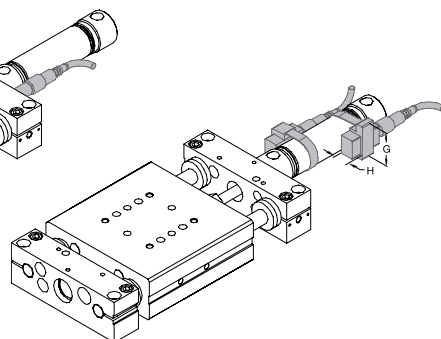

Model	A	B	C	D	E	F	G	H
DLB-06M	13.5 [0.53]	10.2 [0.40]	25.9 [1.02]	--	--	45.7 [1.8]		
DLB-08M				--	--			
DLB-10M	17.8 [0.70]	11.9 [0.47]	31.8 [1.25]	14.7 [0.577]	91.4 [3.60]	63.5 [2.5]	25.4 [1.00]	10.9 [0.43]
DLB-12M	24.1 [0.95]							
DLB-16M								
DLB-20M	51.6 [2.03]	2.5 [0.10]				53.8 [2.12]		
DLB-25M	46.2 [1.82]		48.3 [1.90]					

Dimensions in mm [in]



GR-LIN-35

Dimensions and technical information are subject to change without notice

LINEAR THRUSTER ACCESSORIES

Linear Slides | Accessory Mounting Technical Data

DLT-B, E, L Internally Powered Thruster Slides

Urethane Bumpers & Clamp Collars (DLT-E, L only)

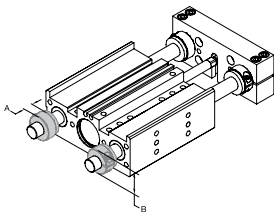

Adjustable Hard Stop & Shock Absorbers

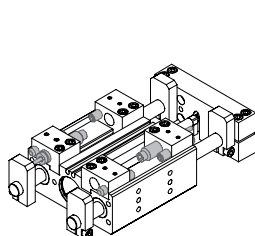

Universal Mounting Kit

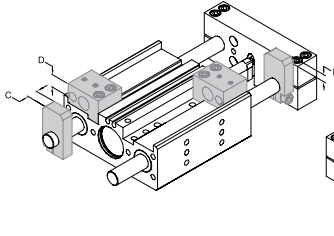

Telescoping Airlines (DLT-E, L only)

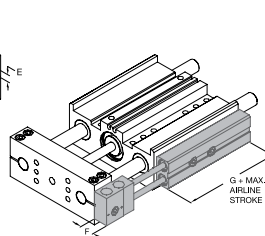

Base Flange Kit (DLT-B only)

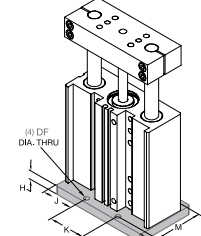

Inductive Proximity Sensors

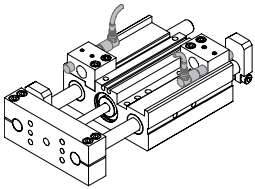

Magneto Resistive Sensors

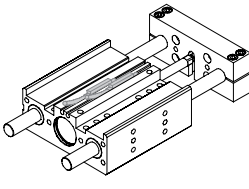

Model	A	B	C	D	E	F	G	H	J	K	L	M
DLT-06M	6.0 [0.236]	12 [0.470]	6.4 [0.250]	7.9 [0.310]	6.9 [0.270]	--	--	3.2 [0.125]	8.0 [0.313]	35 [1.376]	3.2 [0.125]	28.6 [1.125]
DLT-08M		16 [0.630]							14.3 [0.563]			
DLT-10M	8.7 [0.343]	22.1 [0.87]	9.5 [0.375]	12.2 [0.480]	8.1 [0.320]				25.4 [1.000]			38.1 [1.500]
DLT-12M	9.5 [0.375]	23.9 [0.95]		11.4 [0.450]	5.8 [0.230]			9.0 [0.355]	32.5 [1.281]	38.1 [1.500]	4.8 [0.188]	50.8 [2.000]
DLT-16M	11.1 [0.437]	33.3 [1.31]	11.1 [0.437]		8.6 [0.340]	14.7 [0.577]	91.4 [3.60]		42.1 [1.656]			
DLT-20M	12.7 [0.500]	38.1 [1.50]	12.7 [0.500]	22.4 [0.920]	17.0 [0.67]			12.2 [0.480]	44.5 [1.750]	76.2 [3.000]	9.5 [0.375]	76.2 [3.000]
DLT-25M		44.5 [1.75]							57.2 [2.250]			

Dimensions in mm [in]

DLT-T, A, R, U Externally Powered Thruster Slides

Urethane Bumpers & Clamp Collars

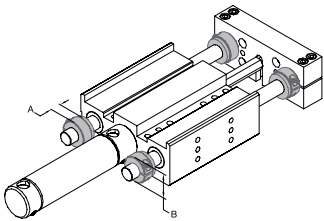

Adjustable Hard Stop & Shock Absorbers

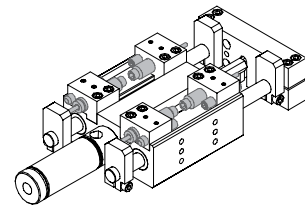

Universal Mounting Kit

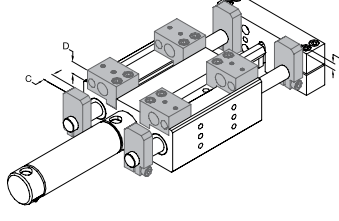

Telescoping Airlines & Flow Controls

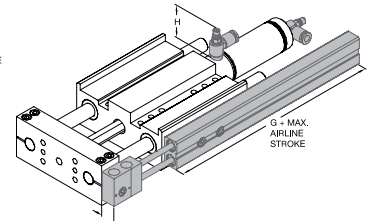

Inductive Proximity Sensors

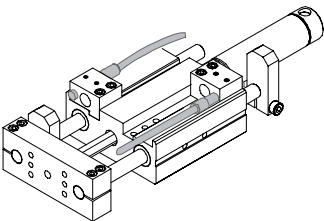

Magneto Resistive Sensors

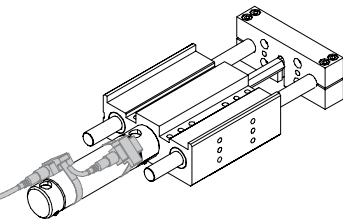

Model	A	B	C	D	E	F	G	H
DLT-06M	6.0 [0.236]	12.0 [0.47]	6.4 [0.250]	7.9 [0.31]	6.9 [0.27]	--	--	46.2 [1.82]
DLT-08M		16.0 [0.63]						
DLT-10M	8.7 [0.343]	22.1 [0.87]	9.5 [0.375]	12.2 [0.480]	8.1 [0.320]			
DLT-12M	9.5 [0.375]	23.9 [0.95]		11.4 [0.450]	5.8 [0.230]			
DLT-16M	11.1 [0.437]	33.3 [1.31]	11.1 [0.437]		8.6 [0.340]	14.7 [0.577]	91.4 [3.60]	28.4 [1.12]
DLT-20M	12.7 [0.500]	38.1 [1.50]	12.7 [0.500]	23.4 [0.92]	17.0 [0.670]			
DLT-25M		44.5 [1.75]						

Dimensions in mm [in]

Dimensions and technical information are subject to change without notice

GR-LIN-36



DLB SERIES - INTERNAL AIR CYLINDER

Internal Air Cylinder Linear Base Slides | Features and Benefits | How To Order

Features:

- Bearing system for smooth operation
- Rugged design produces very reliable long life operation
- Internal air cylinder for space-limited applications
- Telescopic airlines, shocks and hard stops available
- Viton® seals for high temp applications
- Corrosion resistant shafting for corrosive environments
- Inductive sensing for position detection
- Custom stroke lengths available.

Applications:

- Machining and automation applications
- Harsh environment pick-and-place applications
- OEM machines

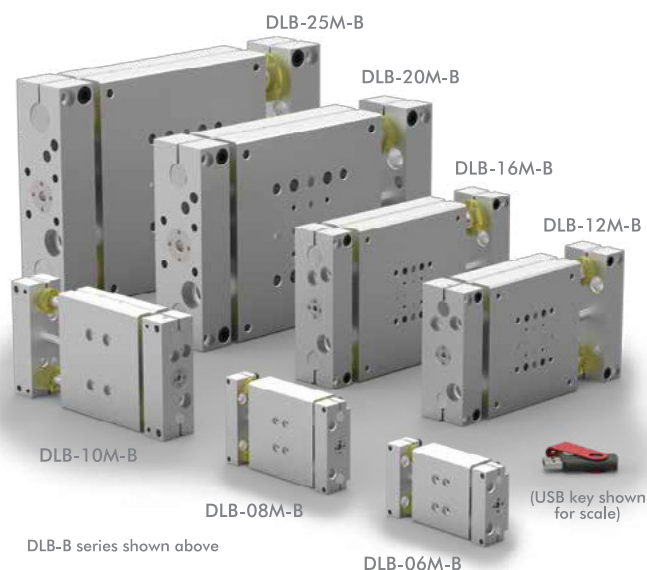

How To Order

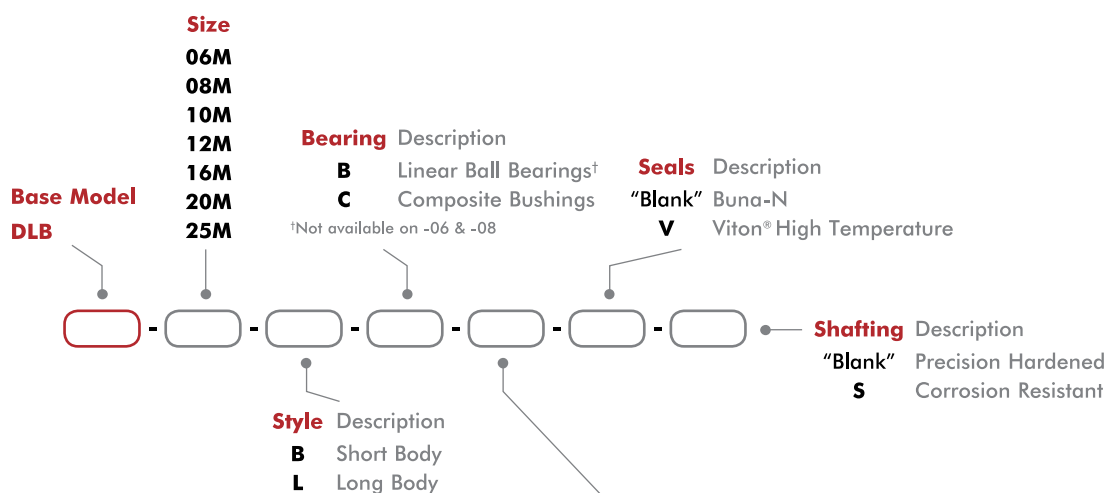

-B Style	Stroke* Metric (mm)
DLB-06M-B	6, 12, 25, 30
DLB-08M-B	6, 12, 25, 40, 44
DLB-10M-B	25, 50
DLB-12M-B	25, 50
DLB-16M-B	25, 50, 80
DLB-20M-B	25, 50, 80, 100
DLB-25M-B	25, 50, 80, 100, 125

-L Style	Stroke* Metric (mm)
DLB-06M-L	12, 25, 40, 50, 65, 75
DLB-08M-L	12, 25, 40, 50, 65, 75, 85
DLB-10M-L	25, 50, 80, 100
DLB-12M-L	25, 50, 80, 100, 125
DLB-16M-L	25, 50, 80, 100, 125, 150
DLB-20M-L	25, 50, 80, 100, 125, 160
DLB-25M-L	25, 50, 80, 100, 125, 160, 175

*Custom strokes available. Consult factory.

*Custom strokes available. Consult factory.



GR-LIN-3

Dimensions and technical information are subject to change without notice

DLB SERIES - INTERNAL AIR CYLINDER

Internal Air Cylinder Linear Base Slides | Accessories and Technical Specifications

Shock/Stop Accessories	Model Numbers	Style	Part Number	Qty/Unit
Shock Absorber	06, 08	ALL	SHOK-030	1-2
	10		SHOK-028	
	12, 16,		SHOK-010	
	20, -25		SHOK-029	
Adjustable Hard Stop	06, 08	ALL	DLT-0623	1-2
	10, 12, 16, 20, 25		DLT-1023	
Sensor Accessories	Model Numbers	Style	Part Number	Qty/Unit
PNP Inductive Sensor with Quick Disconnect*	All Models	ALL	OISP-011	1-2
NPN Inductive Sensor with Quick Disconnect*			OISN-011	
Quick Disconnect 2 Meter Cable Length*			CABL-010	
Quick Disconnect 5 Meter Cable Length*			CABL-013	
Pneumatic Accessories	Model Numbers	Style	Part Number	Qty/Unit
G1/8 Telescopic Airlines (up to 50mm)	10, 12, 16	B	OTAL-043	1-4
G1/8 Telescopic Airlines (up to 80mm)	10, 12, 16		OTAL-044	
G1/8 Telescopic Airlines (up to 100mm)	10, 12, 16	L	OTAL-051	
G1/8 Telescopic Airlines (up to 125mm)	10, 12, 16		OTAL-052	
G1/8 Telescopic Airlines (up to 160mm)	10, 12, 16, 20, 25	L	OTAL-045	1-2
G1/8 Telescopic Airlines (up to 300mm)	20, 25		OTAL-046	
M5 Adjustable Flow Control	06, 08, 10, 12, 16	ALL	VLVF-008	
G 1/8 Adjustable Flow Control	20, 25		VLVF-005	
Cylinder Seal Kit (Buna-N)	06, 08		SLKT-109	1
	10		SLKT-101	
	12, 16	SLKT-103		
	20, 25	SLKT-105		
Cylinder Seal Kit (Viton®)	06, 08	SLKT-109V	1	
	10	SLKT-101V		
	12, 16	SLKT-103V		
	20, 25	SLKT-105V		

* Sensor and cable sold separately.

See page GR-LIN-35 for Accessory Mounting Technical Data.

Specifications

Specifications	Units	06-B, L	08-B, L	10-B, L	12-B, L
Max. Air Pressure	bar [psi]	7 [100]			
Thrust Force @ 5.5 bar [80psi]	N [lbs]	89 [20]		129 [29]	254 [57]
Weight (basic unit) -B	kg [lb]	0.20 [0.44]	0.36 [0.79]	0.93 [2.08]	1.7 [3.83]
Weight (basic unit) -L	kg [lb]	0.32 [0.71]	0.56 [1.24]	1.50 [3.34]	2.30 [5.13]
Additional Weight per Stroke -B	g/mm [lbs/in]	0.53 [0.03]	0.88 [0.05]	1.4 [0.08]	2.1 [0.12]
Cylinder Bore Ø	mm [in]	14.29 [0.563]		19 [0.75]	25 [1.00]
Shaft Ø	mm [in]	6 [0.236]	8 [0.315]	9.5 [0.375]	12 [0.472]

Specifications	Units	16-B, L	20-B, L	25-B, L
Max. Air Pressure	bar [psi]	7 [100]		
Thrust Force @ 5.5 bar [80psi]	N [lbs]	254 [57]	560 [126]	560 [126]
Weight (basic unit) -B	kg [lb]	2.4 [5.19]	5.9 [13.0]	8.2 [18.2]
Weight (basic unit) -L	kg [lb]	3.30 [7.30]	7.1 [15.6]	9.7 [21.4]
Additional Weight per Stroke -B	g/mm [lbs/in]	3.3 [0.19]	5.54 [0.32]	8.4 [0.47]
Cylinder Bore Ø	mm [in]	25 [1.00]	38 [1.5]	38 [1.5]
Shaft Ø	mm [in]	16 [0.630]	20 [0.787]	25 [0.984]

Dimensions and technical information are subject to change without notice

GR-LIN-4



DLB-06/08M-B



Internal Air Cylinder Linear Base Slides | Dimensions and Technical Specifications

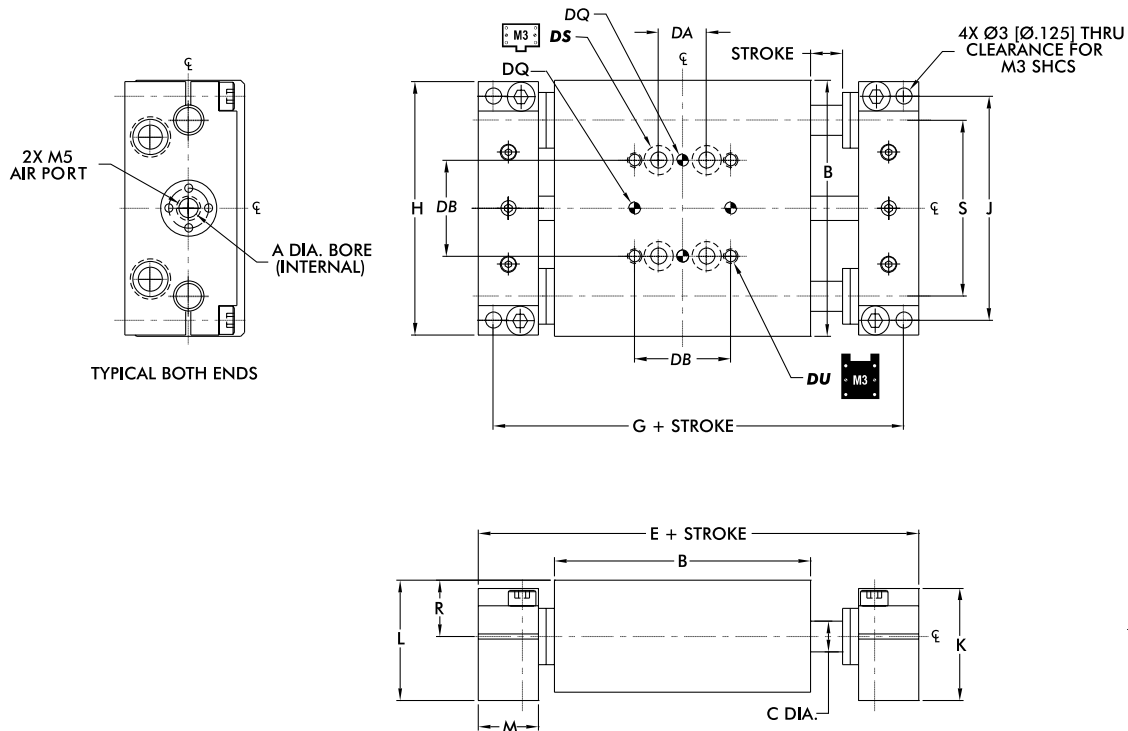

DIRECTCONNECT™ Mounting Pattern Dimensions (all sizes)				
DA	DB	DQ	DS	DU
9.5 [0.375]	19.1 [0.750]	3H7 X 2 DP	CLR & C'BORE FOR M3	M3 x 6 DP

Model	Bore Ø		Body Size		Shaft Ø		Basic Unit Dimensions						
	A	B	C	E	G	H	J	K	L	M	R	S	
DLB-06M	14 [0.563]	50.8 [2.000]	6.0 [0.236]	81.0 [3.19]	75.1 [2.956]	50.3 [1.980]	44.4 [1.750]	22.2 [0.875]	23.7 [0.936]	11.9 [0.470]	11.13 [0.438]	34.93 [1.375]	
DLB-08M		63.5 [2.500]	8.0 [0.315]	93.7 [3.69]	87.8 [3.456]	62.7 [2.470]	57.1 [2.250]					44.45 [1.750]	

Dimensions in mm [in]

Loading Information

- F=Externally applied force
- W=Weight of payload
- F+W=Total force
- M=Maximum moment

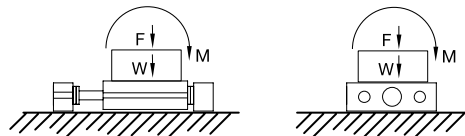

	06	08
Maximum Payload (W) horizontal motion using Shock Absorbers	1.4 kg [3 lbs]	2.3 kg [5 lbs]
Maximum Payload (W) vertical motion using Shock Absorbers	0.7 kg [1.5 lbs]	1.1 kg [2.5 lbs]
Maximum Payload (W) horizontal motion using Urethane Bumpers	0.5 kg [1 lbs]	0.5 kg [1 lbs]
Maximum Total Applied Load + Payload (F+W)	45 N [10 lbs]	53.4 N [12 lbs]
Total Maximum Moment about any Axis (M)	1.7 Nm [15 in-lbs]	3.4 Nm [30 in-lbs]

Shock Absorbers and Flow Controls are recommended for all applications



GR-LIN-5

Dimensions and technical information are subject to change without notice



DLB-06/08M-L

Internal Air Cylinder Linear Base Slides | Dimensions and Technical Specifications

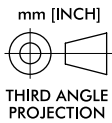
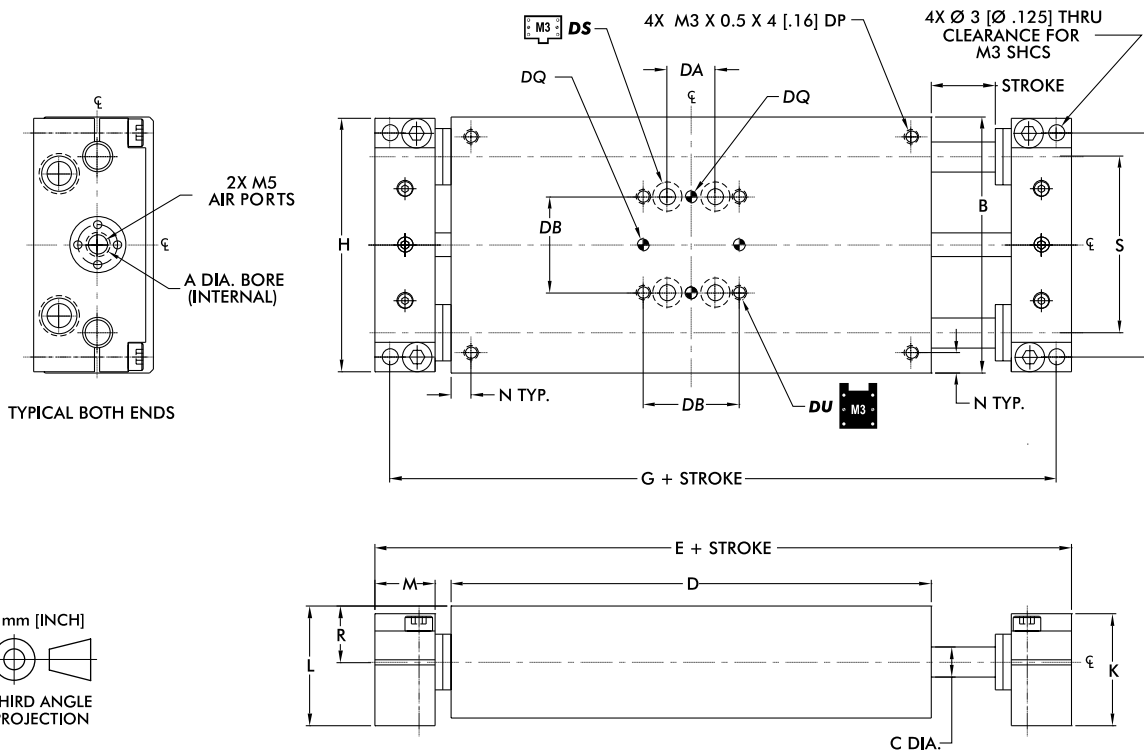

DIRECTCONNECT™ Mounting Pattern Dimensions (all sizes)				
DA	DB	DQ	DS	DU
9.5 [0.375]	19.1 [0.750]	3H7 X 2 DP	CLR & C'BORE FOR M3	M3 X 6 DP

Model	Bore Ø	Body Size	Shaft Ø	Basic Unit Dimensions										
				A	B	C	D	E	G	H	J	K	L	M
DLB-06M	14 [0.563]	50.8 [2.00]	6.0 [0.236]	95.2 [3.75]	125.5 [4.94]	119.6 [4.71]	50.3 [1.980]	44.4 [1.750]	22.2 [0.875]	23.7 [0.936]	11.9 [0.470]	3.96 [0.156]	11.13 [0.438]	34.93 [1.375]
DLB-08M		63.5 [2.50]	8.0 [0.315]	107.9 [4.25]	138.2 [5.44]	132.2 [5.206]	62.7 [2.470]	57.1 [2.250]						44.45 [1.750]

Dimensions in mm [in]

Loading Information

- F=Externally applied force
- W=Weight of payload
- F+W=Total force
- M=Maximum moment

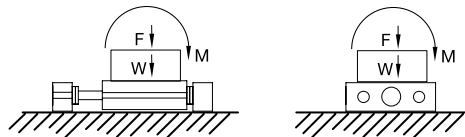

	06	08
Maximum Payload (W) horizontal motion using Shock Absorbers	1.4 kg [3 lbs]	2.3 kg [5 lbs]
Maximum Payload (W) vertical motion using Shock Absorbers	0.7 kg [1.5 lbs]	1.1 kg [2.5 lbs]
Maximum Payload (W) horizontal motion using Urethane Bumpers	0.5 kg [1 lbs]	0.5 kg [1 lbs]
Maximum Total Applied Load + Payload (F+W)	45 N [10 lbs]	53.4 N [12 lbs]
Total Maximum Moment about any Axis (M)	1.7 Nm [15 in-lbs]	3.4 Nm [30 in-lbs]

Shock Absorbers and Flow Controls are recommended for all applications

Dimensions and technical information are subject to change without notice

GR-LIN-6



DLB-10/12/16M-B

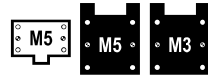

Internal Air Cylinder Linear Base Slides | Dimensions and Technical Specifications

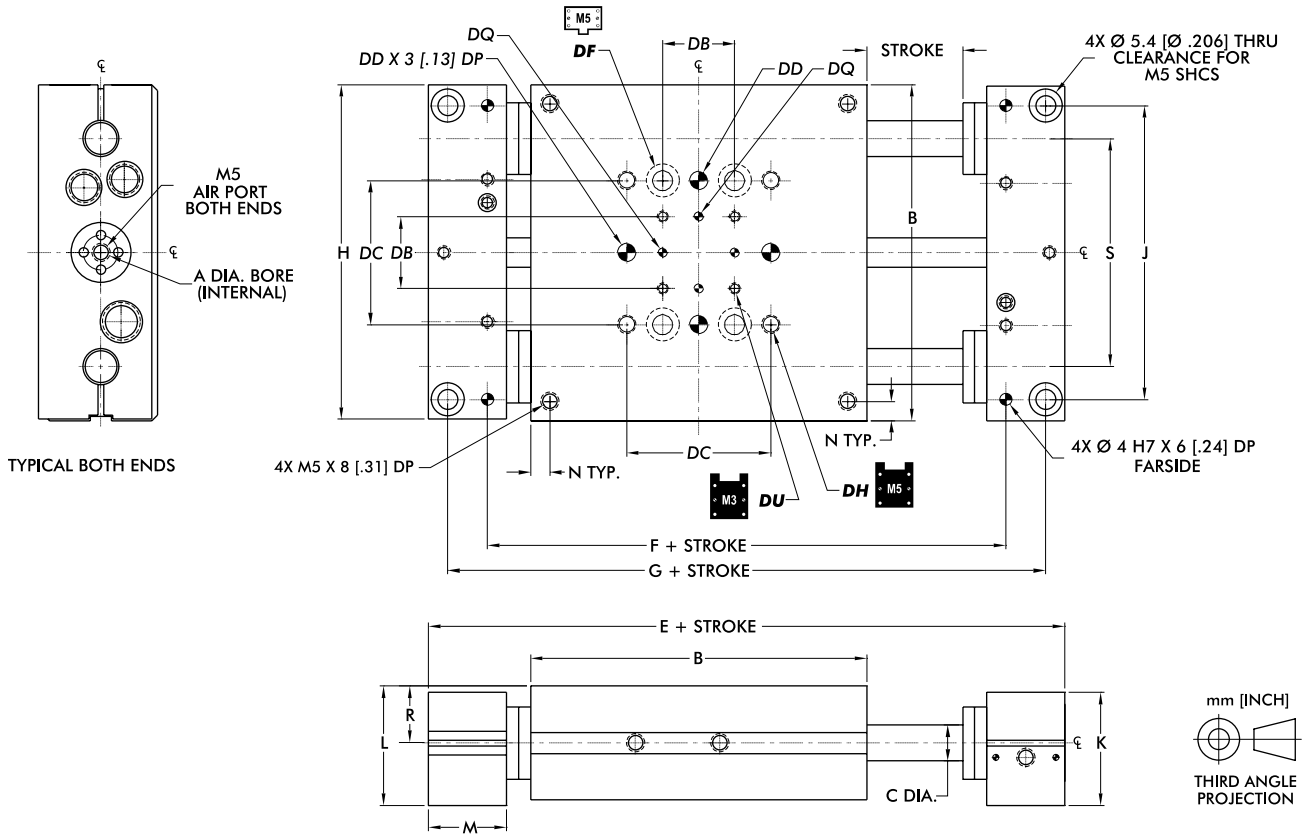

DIRECTCONNECT™ Mounting Pattern Dimensions (all sizes)

DB	DC	DD	DF	DH	DQ	DU
19.1 [0.750]	38.1 [1.500]	5mm H7 X 6 DP	CLEARANCE FOR M5	M5 X 8.5DP	3H7 X 2 DP	M3 X 6 DP

Model	Bore Ø			Basic Unit Dimensions										
	A	B	C	E	F	G	H	J	K	L	M	N	R	S
DLB-10M	19 [0.75]	88.9 [3.50]	9.5 [0.375]	143.0 [5.63]	111.70 [4.3975]	132.8 [5.228]	88.5 [3.485]	77.72 [3.0600]	29.9 [1.178]	31.6 [1.245]		N/A	15.09 [0.594]	60.33 [2.375]
DLB-12M	25 [1.00]	101.6 [4.00]	12 [0.472]	155.7 [6.13]	124.40 [4.8975]	145.5 [5.728]	101.2 [3.985]	88.90 [3.5000]	41.0 [1.615]	42.1 [1.657]	20.7 [0.813]	9.5 [0.375]	20.65 [0.813]	69.85 [2.750]
DLB-16M		120.7 [4.75]	16 [0.630]	174.8 [6.88]	143.45 [5.6475]	164.5 [6.478]	120.3 [4.735]	107.95 [4.2500]						

Dimensions in mm [in]

Loading Information

- F**=Externally applied force
- W**=Weight of payload
- F+W**=Total force
- M**=Maximum moment

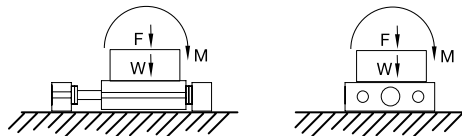

	10	12	16
Maximum Payload (W) horizontal motion using Shock Absorbers	6.8 kg [15 lbs]	13.6 kg [30 lbs]	20.4 kg [45 lbs]
Maximum Payload (W) vertical motion using Shock Absorbers	3.1 kg [7 lbs]	6.8 kg [15 lbs]	9.9 kg [22 lbs]
Maximum Payload (W) horizontal motion using Urethane Bumpers	2.2 kg [5 lbs]	4.5 kg [10 lbs]	6.8 kg [15 lbs]
Maximum Total Applied Load + Payload (F+W)	111 N [25 lbs]	178 N [40 lbs]	311 N [70 lbs]
Total Maximum Moment about any Axis (M)	8.4 Nm [75 in-lbs]	16.9 Nm [150 in-lbs]	33.9 Nm [300 in-lbs]

Shock Absorbers and Flow Controls are recommended for all applications



GR-LIN-7

Dimensions and technical information are subject to change without notice

DIRECTCONNECT™

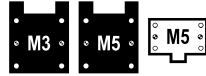

DLB-10/12/16M-L

Internal Air Cylinder Linear Base Slides | Dimensions and Technical Specifications

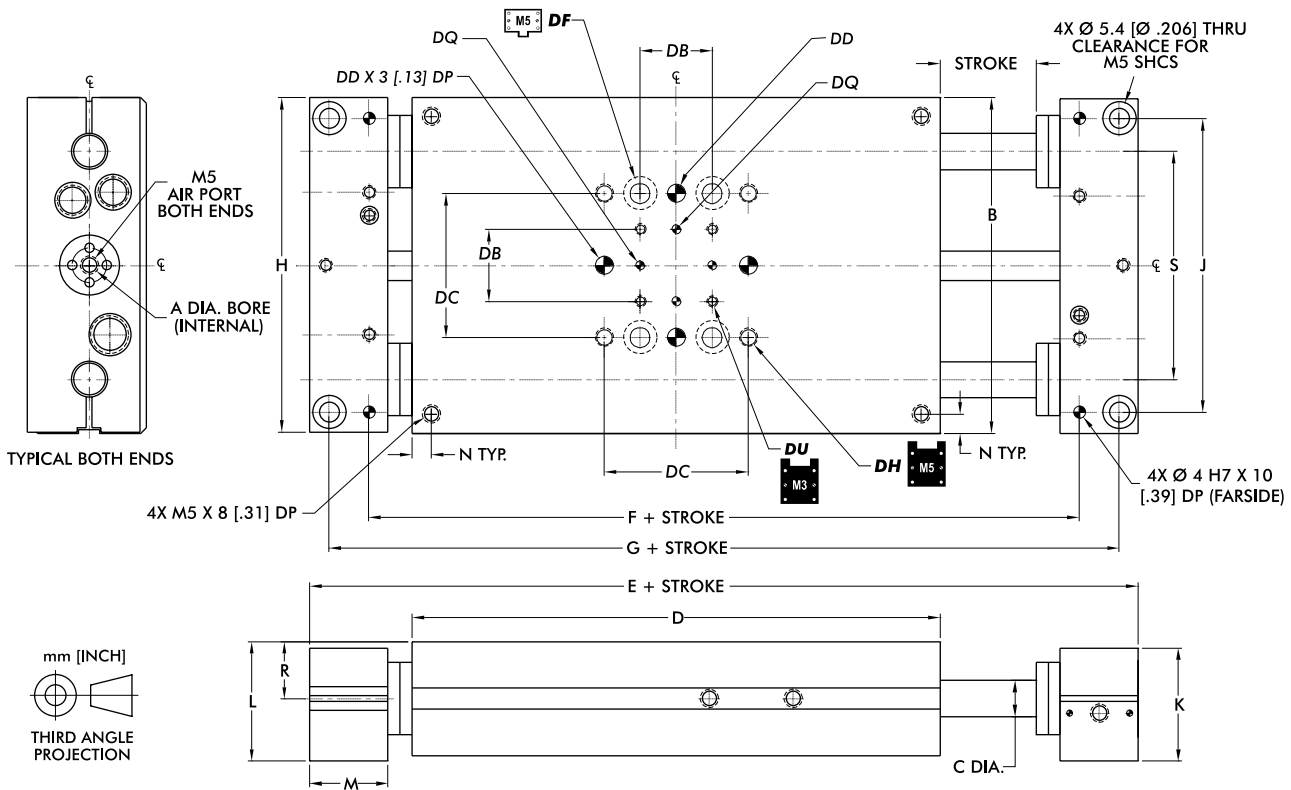

DIRECTCONNECT™ Mounting Pattern Dimensions (all sizes)

DB	DC	DD	DF	DH	DQ	DU
19.1 [0.750]	38.1 [1.500]	5mm H7 X 6 DP	CLEARANCE FOR M5	M5 X 8.5DP	3H7 X 2 DP	M3 X 6 DP

Model	Bore Ø Body Size Shaft Ø			Basic Unit Dimensions											
	A	B	C	D	E	F	G	H	J	K	L	M	N	R	S
DLB-10M	19 [0.75]	88.9 [3.50]	9.5 [0.375]	139.7 [5.50]	193.8 [7.63]	162.50 [6.3975]	183.6 [7.228]	88.5 [3.485]	77.72 [3.0600]	29.9 [1.178]	31.6 [1.245]		N/A	15.09 [0.594]	60.33 [2.375]
DLB-12M	25 [1.00]	101.6 [4.00]	12 [0.472]	165.1 [6.50]	219.2 [8.63]	187.90 [7.3975]	209.0 [8.228]	101.2 [3.985]	88.90 [3.5000]	41.0 [1.615]	42.1 [1.657]	20.7 [0.813]	9.5 [0.375]	20.65 [0.813]	69.85 [2.750]
DLB-16M		120.7 [4.75]	16 [0.630]	190.5 [7.50]	244.6 [9.63]	213.30 [8.3975]	234.4 [9.228]	120.3 [4.735]	107.95 [4.2500]						82.55 [3.250]

Dimensions in mm [in]

Loading Information

- F=Externally applied force
- W=Weight of payload
- F+W=Total force
- M=Maximum moment

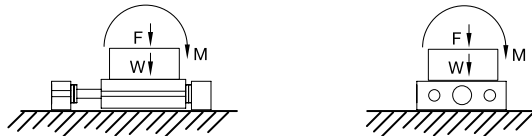

	10	12	16
Maximum Payload (W) horizontal motion using Shock Absorbers	6.8 kg [15 lbs]	13.6 kg [30 lbs]	20.4 kg [45 lbs]
Maximum Payload (W) vertical motion using Shock Absorbers	3.1 kg [7 lbs]	6.8 kg [15 lbs]	9.9 kg [22 lbs]
Maximum Payload (W) horizontal motion using Urethane Bumpers	2.2 kg [5 lbs]	4.5 kg [10 lbs]	6.8 kg [15 lbs]
Maximum Total Applied Load + Payload (F+W)	111 N [25 lbs]	178 N [40 lbs]	311 N [70 lbs]
Total Maximum Moment about any Axis (M)	8.4 Nm [75 in-lbs]	16.9 Nm [150 in-lbs]	33.9 Nm [300 in-lbs]

Shock Absorbers and Flow Controls are recommended for all applications

Dimensions and technical information are subject to change without notice

GR-LIN-8



DLB-20/25M-B

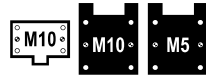

Internal Air Cylinder Linear Base Slides | Dimensions and Technical Specifications

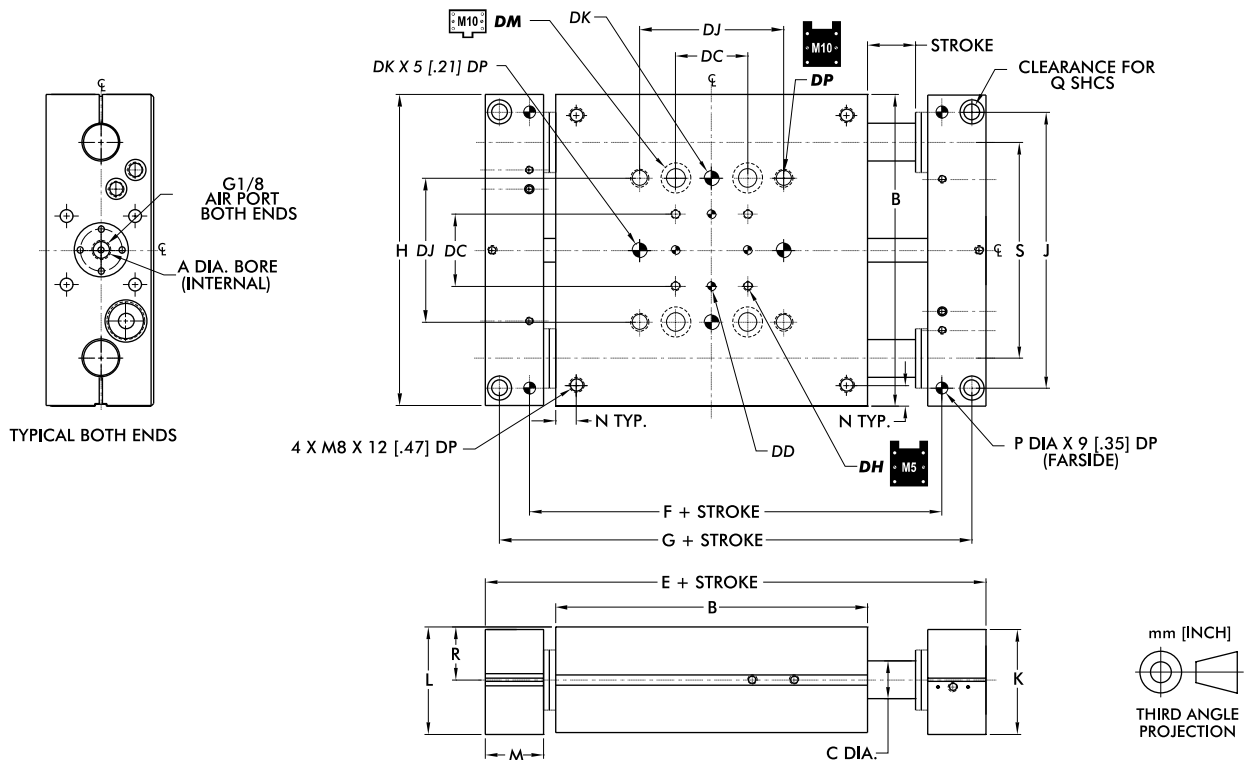

DIRECTCONNECT™ Mounting Pattern Dimensions (all sizes)

DC	DD	DH	DJ	DK	DM	DP
38.1 [1.500]	5 mm H7 X 6 DP	M5 X 8.5 DP	76.2 [3.000]	8 mm H7 X 9.4 DP	CLR & C'BORE FOR M10	M10 X 12 DP

Model	Bore Ø Body Size Shaft Ø			Basic Unit Dimensions												
	A	B	C	E	F	G	H	J	K	L	M	N	P	Q	R	S
DLB-20M	38 [1.50]	165.1 [6.50]	20 [0.787]	239.3 [9.42]	192.66 [7.5850]	224.4 [8.836]	164.6 [6.480]	146.05 [5.7500]	55.4 [2.180]	56.8 [2.236]	[1.210] 30.7	11.1 [0.438]	6.00 [0.2505]	M8	27.94 [1.100]	114.30 [4.500]
DLB-25M		190.5 [7.50]	25 [0.984]	275.3 [10.84]	221.79 [8.7320]	256.7 [10.108]	190.0 [7.480]	171.45 [6.7500]			[1.420] 36.1		8.00 [0.3130]			M10

Dimensions in mm [in]

Loading Information

- F=Externally applied force
- W=Weight of payload
- F+W=Total force
- M=Maximum moment

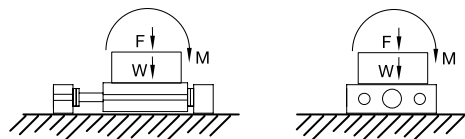

	20	25
Maximum Payload (W) horizontal motion using Shock Absorbers	27.2 kg [60 lbs]	45.3 kg [100 lbs]
Maximum Payload (W) vertical motion using Shock Absorbers	13.6 kg [30 lbs]	22.0 kg [50 lbs]
Maximum Payload (W) horizontal motion using Urethane Bumpers	9.1 kg [20 lbs]	11.3 kg [25 lbs]
Maximum Total Applied Load + Payload (F+W)	444 N [100 lbs]	667 N [150 lbs]
Total Maximum Moment about any Axis (M)	67.7 Nm [600 in-lbs]	135.5 Nm [1200 in-lbs]

Shock Absorbers and Flow Controls are recommended for all applications



GR-LIN-9

Dimensions and technical information are subject to change without notice

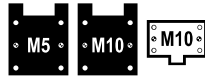

DLB-20/25M-L

Internal Air Cylinder Linear Base Slides | Dimensions and Technical Specifications

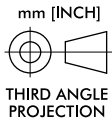
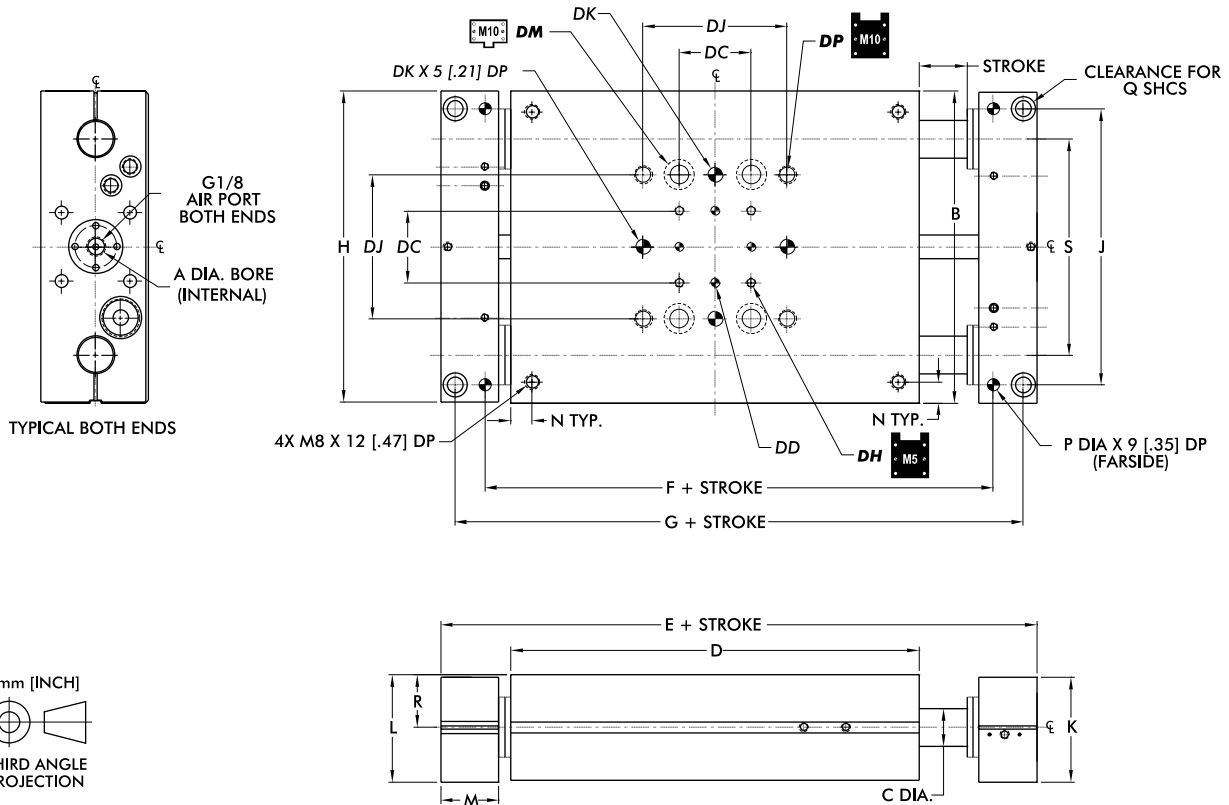

DIRECTCONNECT™ Mounting Pattern Dimensions (all sizes)						
DC	DD	DH	DJ	DK	DM	DP
38.1 [1.500]	5 mm H7 X 6 DP	M5 X 8.5 DP	76.2 [3.000]	8 mm H7 X 9.4 DP	CLR & C'BORE FOR M10	M10 X 12 DP

Model	Bore Ø	Body Size	Shaft Ø	Basic Unit Dimensions													
				A	B	C	D	E	F	G	H	J	K	L	M	N	P
DLB-20M	38 [1.5]	165.1 [6.50]	20 [0.787]	215.9 [8.50]	290.1 [11.42]	243.46 [9.5850]	275.2 [10.836]	164.6 [6.480]	146.05 [5.7500]	55.4 [2.180]	56.8 [2.236]	30.7 [1.210]	11.1 [0.438]	6.00 [0.2505]	M8	27.94 [1.100]	114.30 [4.500]
DLB-25M		190.5 [7.50]	25 [0.984]	241.3 [9.50]	326.1 [12.84]	272.59 [10.7320]	307.5 [12.108]	190.0 [7.480]	171.45 [6.7500]	55.4 [2.180]		36.1 [1.420]		8.00 [0.3130]			M10

Dimensions in mm [in]

Loading Information

- F**=Externally applied force
- W**=Weight of payload
- F+W**=Total force
- M**=Maximum moment

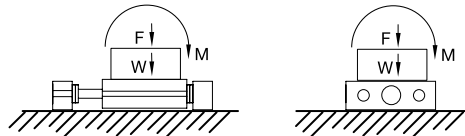

	20	25
Maximum Payload (W) horizontal motion using Shock Absorbers	27.2 kg [60 lbs]	45.3 kg [100 lbs]
Maximum Payload (W) vertical motion using Shock Absorbers	13.6 kg [30 lbs]	22.0 kg [50 lbs]
Maximum Payload (W) horizontal motion using Urethane Bumpers	9.1 kg [20 lbs]	11.3 kg [25 lbs]
Maximum Total Applied Load + Payload (F+W)	444 N [100 lbs]	667 N [150 lbs]
Total Maximum Moment about any Axis (M)	67.7 Nm [600 in-lbs]	[1200 in-lbs]

Shock Absorbers and Flow Controls are recommended for all applications

Dimensions and technical information are subject to change without notice

GR-LIN-10



DLB SERIES - EXTERNAL AIR CYLINDER

External Air Cylinder Linear Base Slides | Features and Benefits | How To Order

Features:

- Bearing system for smooth operation
- Rugged design produces very reliable long life operation
- Replaceable air cylinder with adjustable cushions
- Non-powered Thrusters use customer supplied cylinders
- Urethane bumpers, hardened pads, oil wick
- Optional telescopic airlines transfers air to tooling
- DIRECTCONNECT™ mounting pattern
- Corrosion resistant shafting for corrosive environments
- Position sensing using inductive or magneto resistive sensors

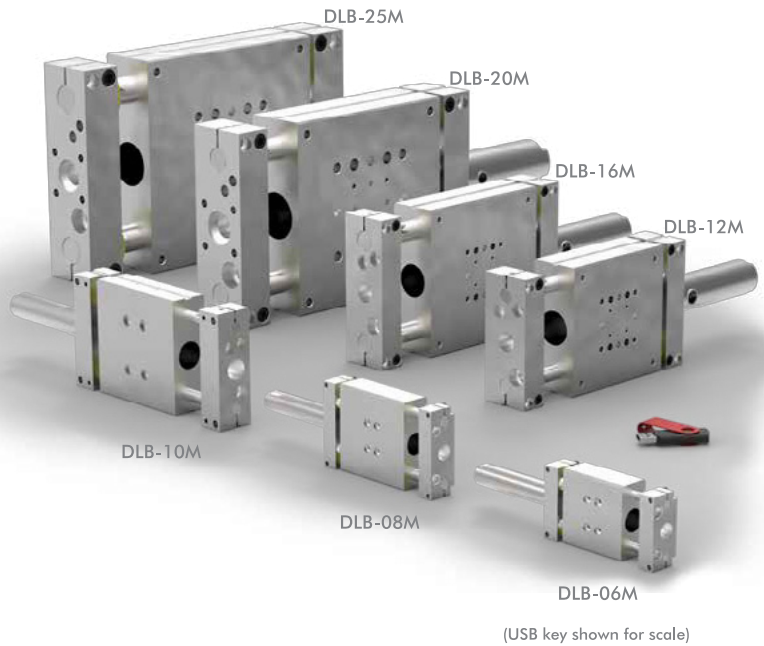

Applications:

- Machining and automation applications
- Harsh environment pick-and-place applications
- OEM machines
- Gantry systems

How To Order

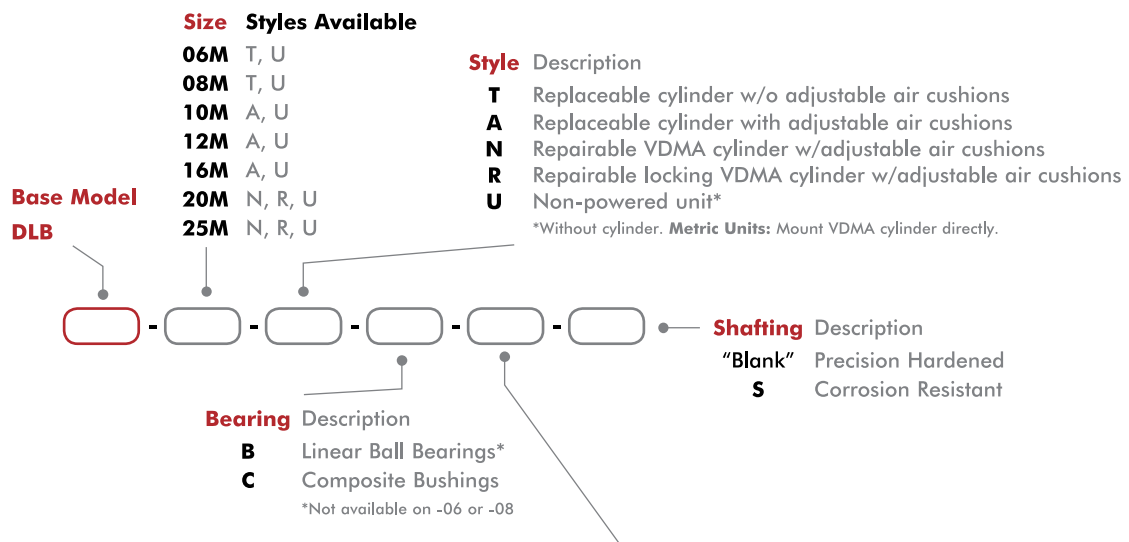

Size	Style	Stroke* Metric (mm)
DLB-06M	T, U	10, 25, 40, 50, 75, 100, 125, 160
DLB-08M	T, U	10, 25, 40, 50, 75, 100, 125, 160, 175, 200
DLB-10M	A, U	25, 50, 80, 100, 125, 160, 200, 250, 300
DLB-12M	A, U	25, 50, 80, 100, 125, 160, 200, 250, 300, 320, 360, 400
DLB-16M	A, U	25, 50, 80, 100, 125, 160, 200, 250, 300, 320, 360, 400, 500
DLB-20M	N, R, U	25, 50, 80, 100, 125, 160, 200, 250, 300, 320, 360, 400, 500
DLB-25M	N, R, U	25, 50, 80, 100, 125, 160, 200, 250, 300, 320, 360, 400, 500

*Custom strokes available. Consult factory.



GR-LIN-11

Dimensions and technical information are subject to change without notice

DLB SERIES - EXTERNAL AIR CYLINDER

External Air Cylinder Linear Base Slides | Accessories

Shock/Stop Accessories	Model Sizes	Style	Part Number	Qty/Unit
Shock Absorber	06, 08	All	SHOK-030	1-2
	10		SHOK-028	
	12, 16,		SHOK-010	
	20, 25		SHOK-029	
Adjustable Hard Stop	06, 08		DLT-0623	
	10, 12, 16, 20, 25		DLT-1023	

Sensor Accessories	Model Sizes	Style	Part Number	Qty/Unit
PNP Inductive Sensor with Quick Disconnect*	All Models	All	OISP-011	1-2
NPN Inductive Sensor with Quick Disconnect*			OISN-011	
PNP Magneto Resistive Sensor w/Qk Disconnect*	06, 08, 10, 12, 16	T, A	OHSP-005	
NPN Magneto Resistive Sensor w/Quick Disconnect*			OHSN-005	
PNP Magneto Resistive Sensor w/Qk Disconnect*	20, 25	N, R	OHSP-020	
NPN Magneto Resistive Sensor w/Qk Disconnect*			OHSN-020	
Quick Disconnect 2 Meter Cable Length*	All Models	All	CABL-010	
Quick Disconnect 5 Meter Cable Length*			CABL-013	
Cable Extension Cord 1M Length*	All Models	All	CABL-015	
Cable Extension Cord 2M Length*			CABL-016	

Pneumatic Accessories	Model Sizes	Style	Part Number	Qty/Unit
G1/8 Telescopic Airlines (up to 160mm)	10, 12, 16	All	OTAL-045	1-4
G1/8 Telescopic Airlines (up to 300mm)	10, 12, 16		OTAL-046	
G1/8 Telescopic Airlines (up to 450mm)	10, 12, 16, 20, 25		OTAL-047	
G1/8 Telescopic Airlines (up to 600mm)	20M, 25M		OTAL-048	
G1/8 Adjustable Flow Control	10, 12, 16, 20, 25		VLVF-005	1-2
G1/8 Male to 1/8 NPT Adapter	20, 25		PLFT-025	

* Sensor and cable sold separately.

See page GR-LIN-35 for Accessory Mounting Technical Data.

DLB SERIES - EXTERNAL AIR CYLINDER

External Air Cylinder Linear Base Slides | Technical Specifications

Specifications	Units	06-T, U	08-T, U	10-A, U	12-A, U
Max. Air Pressure	bar [psi]	7 [100]			
Thrust Force @ 5.5 bar [80psi]	N [lbs]	89 [20]		145 [31]	289 [65]
Weight (basic unit)	kg [lb]	0.15 [0.34]	0.31 [0.69]	0.90 [1.98]	1.66 [3.73]
Additional Weight per Stroke	g/mm [lbs/in]	0.88 [0.05]	1.23 [0.07]	1.4 [0.09]	2.9 [0.16]
Cylinder Bore Ø	mm [in]	16 [0.563]		20 [0.75]	25 [1.00]
Shaft Ø	mm [in]	6 [0.236]	8 [0.315]	9.5 [0.375]	12 [0.472]
Maximum Moment Load	N-m [in-lbs]	1.7 [15]	3.4 [30]	8.4 [75]	16.9 [150]

Specifications	Units	16-A, U	20-A, N, R, U	25-A, N, R, U
Max. Air Pressure	bar [psi]	7 [100]		
Thrust Force @ 5.5 bar [80psi]	N [lbs]	289 [65]	443 [100]	443 [100]
Weight (basic unit)	kg [lb]	2.3 [5.03]	5.9 [12.9]	8.3 [18.0]
Additional Weight per Stroke	g/mm [lbs/in]	4.2 [0.23]	9.5 [0.53]	12.1 [0.68]
Cylinder Bore Ø	mm [in]	25 [1.00]	32 [1.25]	32 [1.25]
Shaft Ø	mm [in]	16 [0.630]	20 [0.787]	25 [0.984]
Maximum Moment Load	N-m [in-lbs]	33.9 [300]	67.8 [600]	135 [1200]
Min. Air Pressure to Release Cylinder Lock -R	bar [psi]		4 [60]	4 [60]
Holding Force of Locking Mechanism -R	N [lbs]		550 [123]	550 [123]

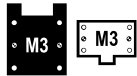

DLB-06/08M-T, U

External Air Cylinder Linear Base Slides | Dimensions and Technical Specifications

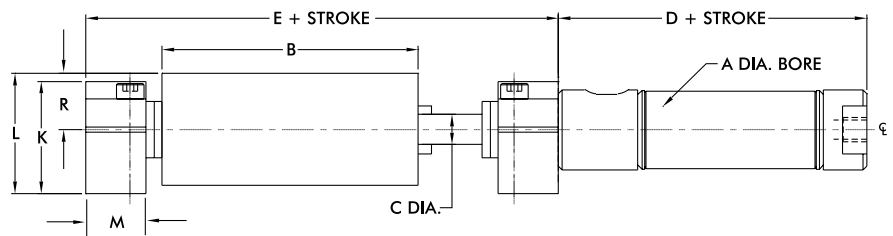
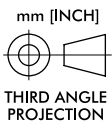
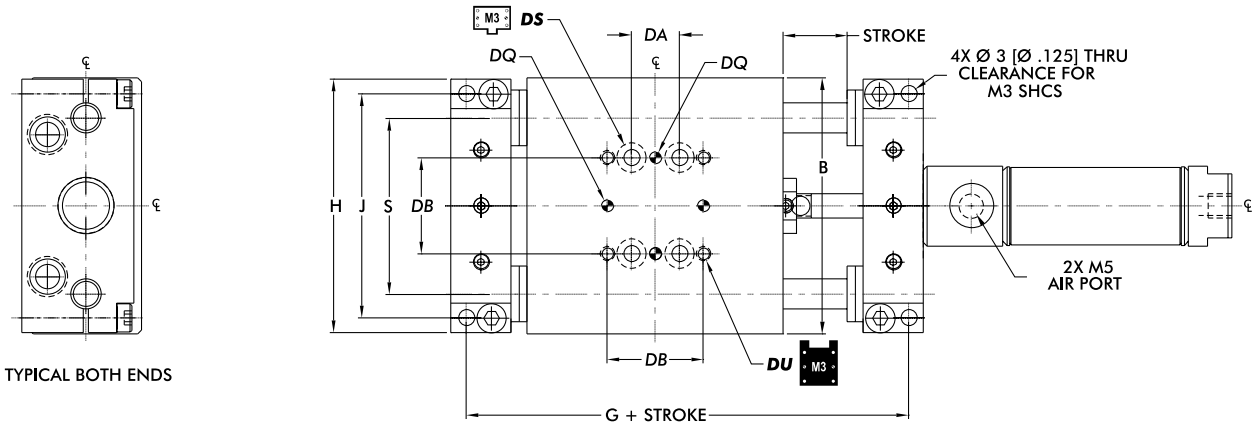

DIRECTCONNECT™ Mounting Pattern Dimensions (all sizes)				
DA	DB	DQ	DS	DU
9.5 [0.375]	19.1 [0.750]	3H7 X 2 DP	CLR & C'BORE FOR M3	M3 x 6 DP

Model	Bore Ø			Body Size			Shaft Ø			Basic Unit Dimensions						
	A	B	C	D	E	G	H	J	K	L	M	R	S			
DLB-06M	16 [0.563]	50.8 [2.00]	6.0 [0.236]	48.4 [1.91]	81.0 [3.19]	75.1 [2.956]	50.3 [1.980]	44.4 [1.750]	22.2 [0.875]	23.7 [0.936]	11.9 [0.470]	11.13 [0.438]	34.93 [1.375]			
DLB-08M		63.5 [2.50]	8.0 [0.315]		93.7 [3.69]	87.8 [3.456]	62.7 [2.470]	57.1 [2.250]					44.45 [1.750]			

Dimensions in mm [in]

Loading Information

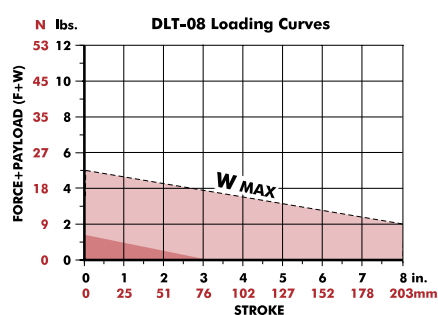
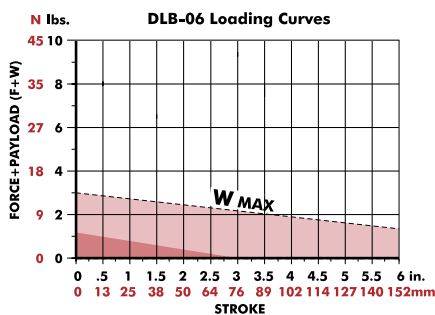

Shock Absorbers and Flow Controls are recommended for all applications

F=Externally applied force
W=Weight of payload
F+W=Total force

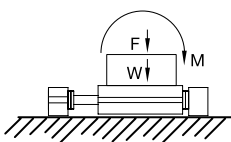

(W) in this range use **Single Shock** in both directions

(W) in this range use **Bumpers or Cushioned Cylinder**

Shaded shock absorption ranges of horizontal payload (W) @ 80psi, flow controls fully open. For vertical applications do not exceed 1/2 of the recommended payload due to the additional acceleration effect of gravity.

Dimensions and technical information are subject to change without notice

GR-LIN-14



DLB-10/12/16M-A, U

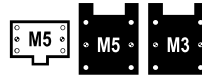

External Air Cylinder Linear Base Slides | Dimensions and Technical Specifications

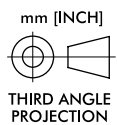
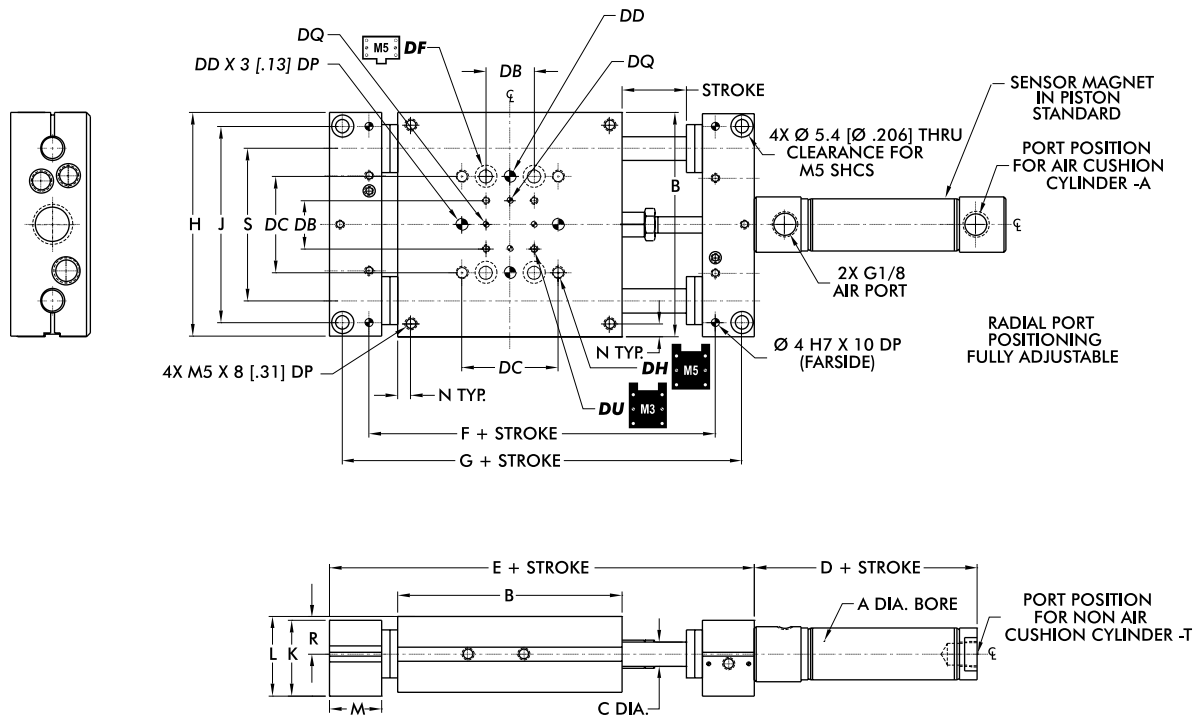

DIRECTCONNECT™ Mounting Pattern Dimensions (all sizes)						
DB	DC	DD	DF	DH	DQ	DU
19.1 [0.750]	38.1 [1.500]	5mm H7 X 6 DP	CLEARANCE FOR M5	M5 X 8.5DP	3H7 X 2 DP	M3 X 6 DP

Model	Bore Ø	Body Size	Shaft Ø	Basic Unit Dimensions											
				A	B	C	D	E	F	G	H	J	K	L	M
DLB-10M	20 [0.75]	88.9 [3.50]	9.5 [0.375]	88.0 [2.91]	149.4 [5.63]	118.05 [4.3975]	139.1 [5.228]	88.5 [3.485]	77.7 [3.060]	29.9 [1.178]	31.6 [1.245]		N/A	15.09 [0.594]	60.33 [2.375]
DLB-12M	25 [1.00]	101.6 [4.00]	12 [0.472]	91.5 [2.88]	162.1 [6.13]	130.75 [4.8975]	151.8 [5.728]	101.2 [3.985]	88.9 [3.500]	41.0 [1.615]	42.1 [1.657]	20.7 [0.813]	9.5 [0.375]	20.65 [0.813]	69.85 [2.750]
DLB-16M		120.7 [4.75]	16 [0.630]		181.1 [6.88]	149.80 [5.6475]	170.9 [6.478]	120.3 [4.735]	107.9 [4.250]						82.55 [3.250]

Dimensions in mm [in]

Loading Information

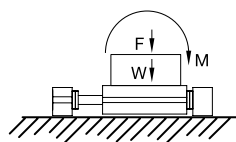
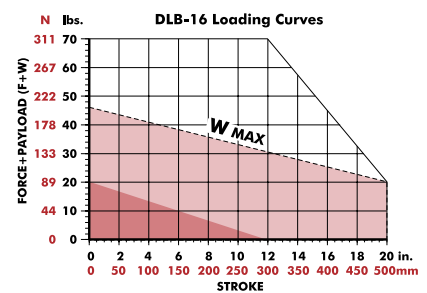
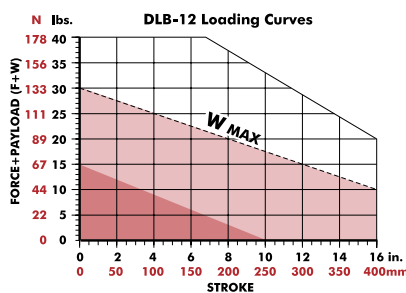
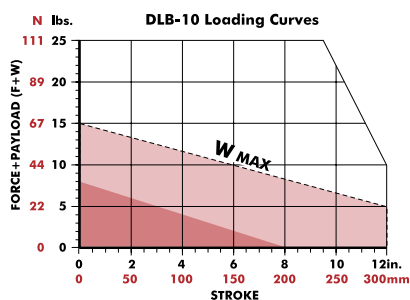

F=Externally applied force
W=Weight of payload
F+W=Total force

Shock Absorbers and Flow Controls are recommended for all applications

(W) in this range use **Single Shock** in both directions

(W) in this range use **Bumpers or Cushioned Cylinder**

Shaded shock absorption ranges of horizontal payload (W) @ 80psi, flow controls fully open. For vertical applications do not exceed 1/2 of the recommended payload due to the additional acceleration effect of gravity.



GR-LIN-15

Dimensions and technical information are subject to change without notice

DIRECTCONNECT™

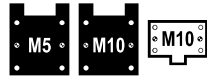

DLB-20/25M-A, R, U

External Air Cylinder Linear Base Slides | Dimensions and Technical Specifications

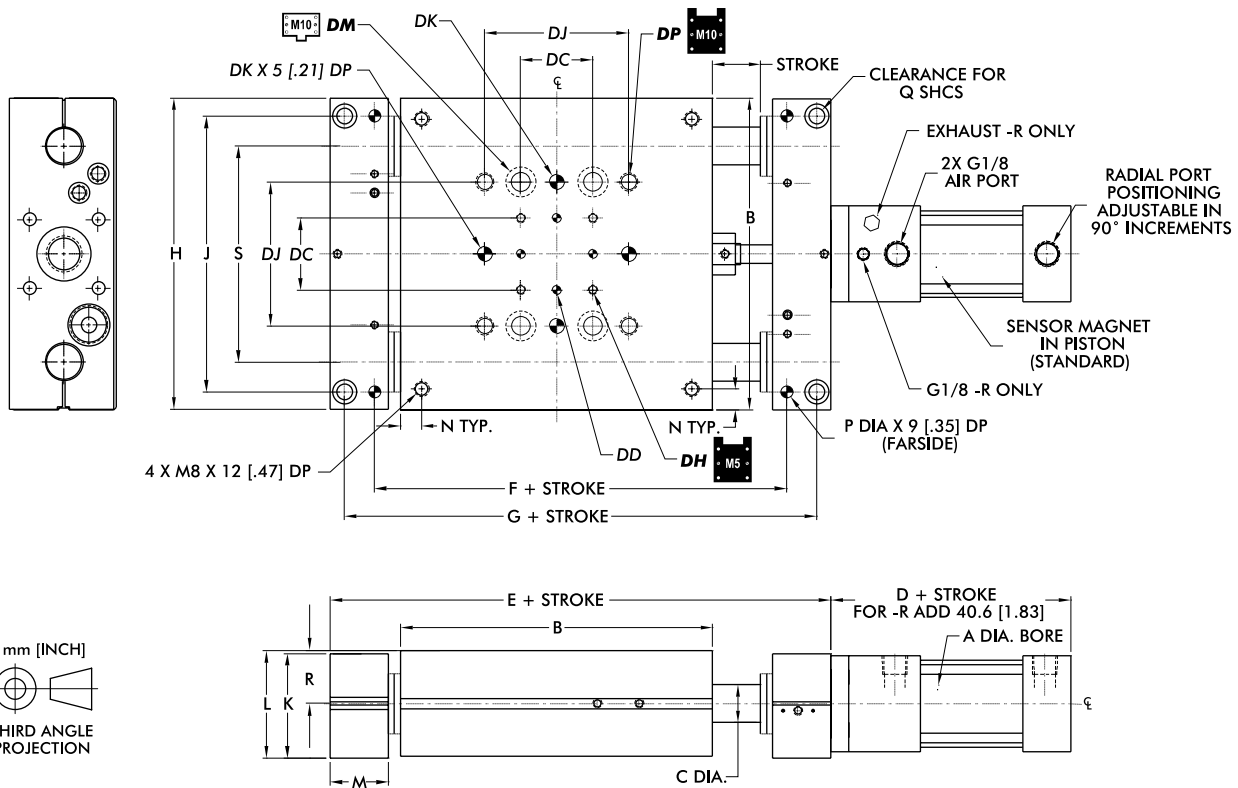

mm [INCH]
THIRD ANGLE PROJECTION

DIRECTCONNECT™ Mounting Pattern Dimensions (all sizes)						
DC	DD	DH	DJ	DK	DM	DP
38.1 [1.500]	5 mm H7 X 6 DP	M5 X 8.5 DP	76.2 [3.000]	8 mm H7 X 9.4 DP	CLR & C'BORE FOR M10	M10 X 12 DP

Model	Bore Ø Body Ø Shaft Ø			Basic Unit Dimensions													
	A	B	C	D	E	F	G	H	J	K	L	M	N	P	Q	R	S
DLB-20M	32 [1.25]	165.1 [6.50]	20 [0.787]	98.0 [3.63]	239.3 [9.42]	192.66 [7.5850]	224.4 [8.836]	164.6 [6.480]	146.05 [5.7500]	55.4 [2.180]	56.8 [2.236]	30.7 [1.210]	11.1 [0.438]	6.00 [0.2505]	M8	27.94 [1.100]	114.30 [4.500]
DLB-25M		190.5 [7.50]	25 [0.984]		275.3 [10.84]	221.79 [8.7320]	256.7 [10.108]	190.0 [7.480]	171.45 [6.7500]			36.1 [1.420]		8.00 [0.3130]	M10		113.35 [5.250]

Dimensions in mm [in]

Loading Information

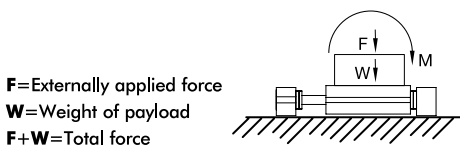
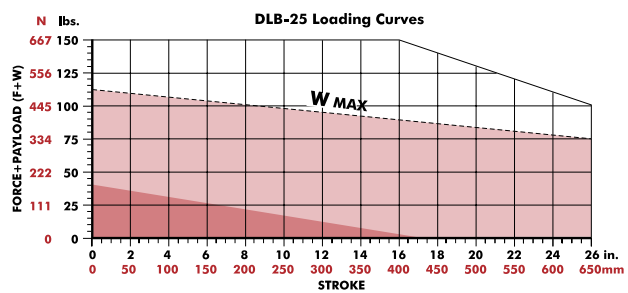
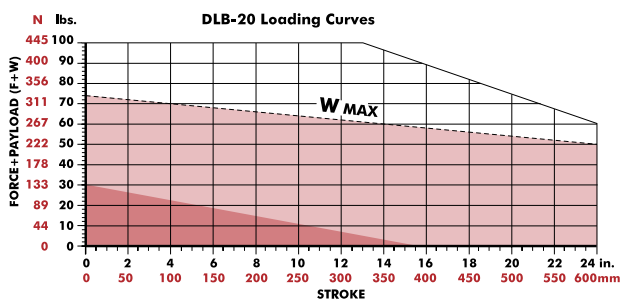

Shock Absorbers and Flow Controls are recommended for all applications

(W) in this range use Single Shock in both directions

(W) in this range use Bumpers or Cushioned Cylinder

Shaded shock absorption ranges of horizontal payload (W) @ 80psi, flow controls fully open. For vertical applications do not exceed 1/2 of the recommended payload due to the additional acceleration effect of gravity.

Dimensions and technical information are subject to change without notice

GR-LIN-16



DLT SERIES - INTERNAL AIR CYLINDER

Internal Air Cylinder Linear Thruster Slides | Features and Benefits | How To Order

Features:

- 3 Models: **-B** block style, **-E** short body & **-L** long body
- Bearing system for smooth operation
- Rugged design produces very reliable long life operation
- Internal air cylinder for space-limited applications
- Urethane bumpers, hardened pads, oil wick
- Optional telescopic airlines transfers air to tooling
- DIRECTCONNECT™ mounting pattern
- Corrosion resistant shafting for corrosive environments
- Position sensing using inductive or magneto resistive sensors
- Viton® seals for high temperature applications
- Base Flange Kit (**-B** only) converts unit into a lift table

Applications:

- Machining, harsh environment, pick-and-place automation applications
- Lift table applications

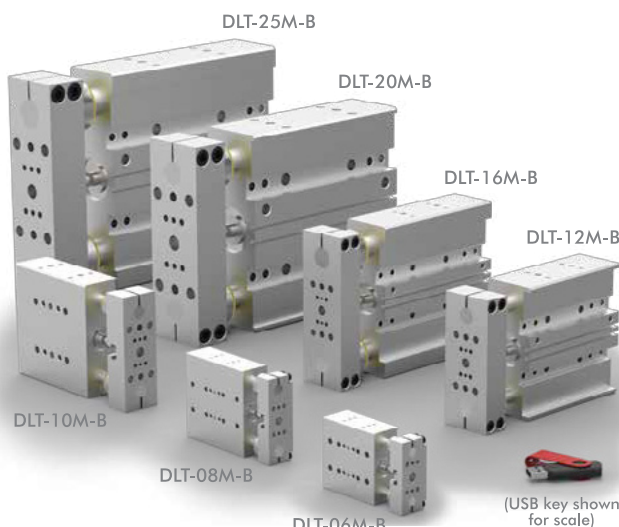

How To Order

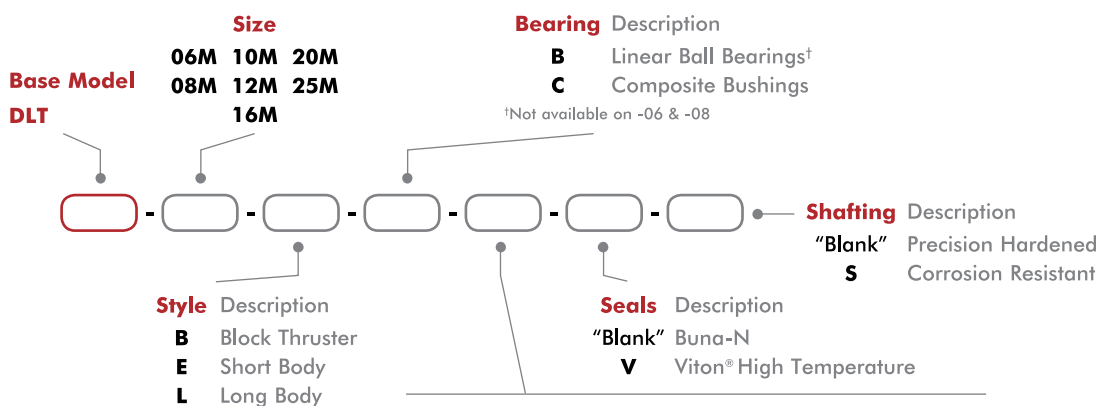

-B Style **Stroke*** Metric (mm)

DLT-06M-B	6, 12, 25, 30
DLT-08M-B	6, 12, 25, 30, 40, 44
DLT-10M-B	12, 25, 40, 50
DLT-12M-B	12, 25, 40, 50
DLT-16M-B	12, 25, 40, 50, 65, 75
DLT-20M-B	12, 25, 40, 50, 65, 75, 85, 100
DLT-25M-B	12, 25, 40, 50, 65, 75, 85, 100, 115, 125

-E Style **Stroke*** Metric (mm)

DLT-06M-E	6, 12, 25, 30
DLT-08M-E	6, 12, 25, 40, 44
DLT-10M-E	25, 50
DLT-12M-E	25, 50
DLT-16M-E	25, 50, 75
DLT-20M-E	25, 50, 75, 100
DLT-25M-E	25, 50, 75, 100, 125

-L Style **Stroke*** Metric (mm)

DLT-06M-L	12, 25, 40, 50, 65, 75
DLT-08M-L	12, 25, 40, 50, 65, 75, 85
DLT-10M-L	25, 50, 80, 100
DLT-12M-L	25, 50, 80, 100, 125
DLT-16M-L	25, 50, 80, 100, 125, 150
DLT-20M-L	25, 50, 75, 100, 125, 160
DLT-25M-L	25, 50, 75, 100, 125, 160, 175

*Custom strokes available. Consult factory.



GR-LIN-17

Dimensions and technical information are subject to change without notice

DLT SERIES - INTERNAL AIR CYLINDER

Internal Air Cylinder Linear Thruster Slides | Accessories

Shock/Stop & Mounting Accessories	Model Numbers	Style	Part Number	Qty/Unit
Universal Mounting Kit (Stop/Shock)	06	All	OSAK-069	1-2 on -B 1-4 on -E, -L
	08		OSAK-070	
Universal Mounting Kit (Stop/Shock/Sensor)	10		OSAK-055	
	12		OSAK-057	
	16		OSAK-059	
	20		OSAK-061	
	25		OSAK-063	
Shock Absorber	06, 08		SHOK-030	
	10		SHOK-028	
	12, 16,		SHOK-010	
	20, 25	SHOK-029		
Adjustable Hard Stop	06, 08	DLT-0623		
	10, 12, 16, 20, 25	DLT-1023		
Urethane Bumper/Stop Collar Kit	06	E, L	OSAK-067	1
	08		OSAK-068	
	10		OSAK-065	
	12		OSAK-066	
	16		OSAK-060	
	20		OSAK-062	
	25		OSAK-064	
Base Flange Kit	See Datasheet	B	--	

Sensor Accessories	Model Numbers	Style	Part Number	Qty/Unit
Inductive Sensor Mounting Kit	06	All	OSMK-076	1 on -B 1-2 on -E, -L 1-2
	08		OSMK-077	
PNP Inductive Sensor with Quick Disconnect*	06, 08		OISP-014	
NPN Inductive Sensor with Quick Disconnect*			OISN-014	
PNP Inductive Sensor with Quick Disconnect*	10, 12, 16, 20, 25		OISP-011	
NPN Inductive Sensor with Quick Disconnect*			OISN-011	
PNP Magneto Resistive with Quick Disconnect*			All Models	
NPN Magneto Resistive with Quick Disconnect*	OHSN-017			
Quick Disconnect 2 Meter Cable Length*	All Models		CABL-010	
Quick Disconnect 5 Meter Cable Length*			CABL-013	

* Sensor and cable sold separately.

Pneumatic Accessories	Model Numbers	Style	Part Number	Qty/Unit
G1/8 Telescopic Airlines (up to 50mm)	10, 12, 16	B, E	OTAL-043	1-4
G1/8 Telescopic Airlines (up to 80mm)		B, E, L	OTAL-044	
G1/8 Telescopic Airlines (up to 100mm)	20, 25	B, E	OTAL-051	
G1/8 Telescopic Airlines (up to 125mm)			OTAL-052	
G1/8 Telescopic Airlines (up to 160mm)	10, 12, 16	L	OTAL-045	
G1/8 Telescopic Airlines (up to 300mm)			OTAL-046	
M5 Adjustable Flow Control	06, 08, 10, 12, 16	All	VLVF-008	1-2
G1/8 Adjustable Flow Control			VLVF-005	
Seal Kits	See Datasheets			1

See page GR-LIN-36 for Accessory Mounting Technical Data.

DLT SERIES - INTERNAL AIR CYLINDER

Internal Air Cylinder Linear Thruster Slides | Technical Specifications

Specifications	Units	06-B, E	06-L	08-B, E	08-L	10-B, E	10-L	12-B, E	12-L
Max. Air Pressure	bar [psi]	7 [100]							
Thrust Force @ 5.5 bar [80psi]	N [lbs]	89 [20]				155 [35]		275 [62]	
Weight -B (basic unit)	kg [lb]	0.15 [0.34]	--	0.30 [0.65]	--	0.82 [1.81]	--	1.31 [2.88]	--
Weight -E, L (basic unit)	kg [lb]		0.28 [0.61]		0.44 [0.96]	0.84 [1.87]	0.88 [1.95]	1.35 [2.98]	1.46 [3.21]
Cylinder Bore Ø	mm [in]	14.3 [0.563]				19 [0.75]		25 [1.0]	
Shaft Ø	mm [in]	6 [0.236]		8 [0.315]		9.5 [0.375]		12 [0.472]	
Max (M) Vertical Motion	Nm [in-lbs]	0.6 [5]		1.1 [10]		2.8 [25]		5.6 [50]	

Specifications	Units	16-B, E	16-L	20-B, E	20-L	25-B, E	25-L
Max. Air Pressure	bar [psi]	7 [100]					
Thrust Force @ 5.5 bar [80psi]	N [lbs]	275 [62]		622 [140]			
Weight -B (basic unit)	kg [lb]	1.99 [4.38]	--	5.1 [11.6]	--	7.2 [15.7]	--
Weight -E, L (basic unit)	kg [lb]	2.07 [4.56]	2.03 [4.81]	5.2 [11.6]	5.5 [12.0]	7.4 [16.4]	7.9 [17.4]
Cylinder Bore Ø	mm [in]	25 [1.0]		38 [1.5]			
Shaft Ø	mm [in]	16 [0.630]		20 [0.787]		25 [0.984]	
Max (M) Vertical Motion	Nm [in-lbs]	11.3 [100]		28.2 [250]		56.4 [500]	

DIRECTCONNECT™



DLT-06/08M-B

Internal Air Cylinder Linear Thruster Slides | Dimensions and Technical Specifications

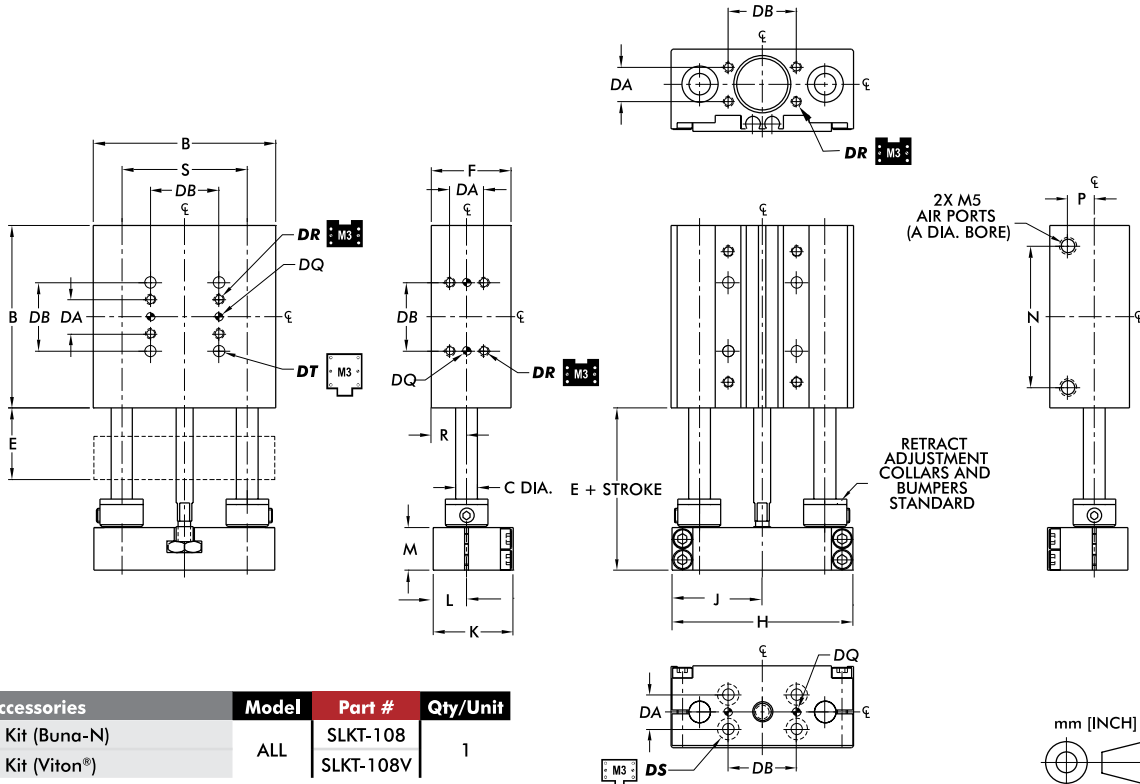

2X M5 AIR PORTS (A DIA. BORE)
RETRACT ADJUSTMENT COLLARS AND BUMPERS STANDARD

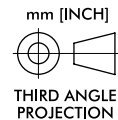

Pneumatic Accessories	Model	Part #	Qty/Unit
Cylinder Seal Kit (Buna-N)	ALL	SLKT-108	1
Cylinder Seal Kit (Viton®)		SLKT-108V	1

Mounting Accessories	Model	Part #	Qty/Unit
Base Flange Kit (Imperial & Metric)	06	ODLT-015	1
	08	ODLT-016	

DIRECTCONNECT™ Mounting Pattern Dimensions (all sizes)					
DA	DB	DQ	DR	DS	DT
9.5 [0.375]	19.1 [0.750]	3H7 X 2 DP	M3 x 6 DP	CLR & C'BORE FOR M3	CLR & C'BORE FOR M3

Model	Bore Ø			Body Size			Shaft Ø			Basic Unit Dimensions						
	A	B	C	E	F	H	J	K	L	M	N	P	R	S		
DLT-06M	14	50.8 [2.00]	6.0 [0.236]	19.9	22.4 [0.88]	50.3 [1.980]	25.1 [0.990]	22.2 [0.875]	9.3 [0.365]	11.9 [0.470]	39.4 [1.55]	7.4 [0.29]	9.9 [0.390]	34.93 [1.375]		
DLT-08M		63.5 [2.50]	8.0 [0.315]			62.7 [2.470]	31.0 [1.235]				52.1 [2.05]			44.45 [1.75]		

Dimensions in mm [in]

Loading Information

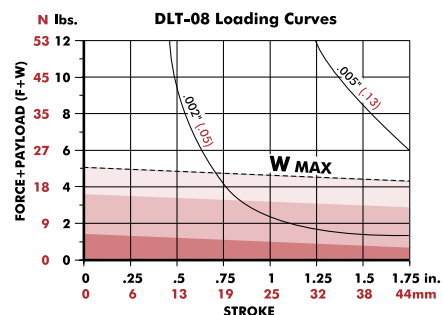
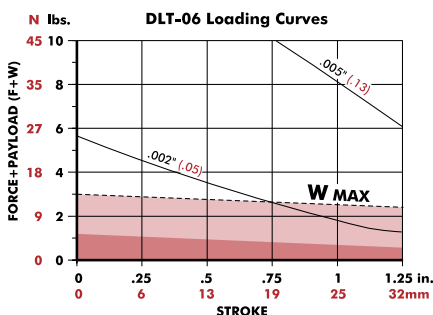

F=Externally applied force
W=Weight of payload
F+W=Total force
M=Maximum moment (in-lb. or N-m)

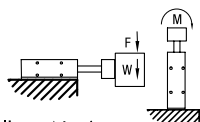

Shock Absorbers and Flow Controls are recommended for all applications

Use Double Shocks in both directions Use Single Shock in both directions Use Bumpers or Cushioned Cylinder

Shaded shock absorption ranges of horizontal payload (W) @ 80psi, flow controls fully open. For vertical applications do not exceed 1/2 of the recommended payload due to the additional acceleration effect of gravity.

Dimensions and technical information are subject to change without notice

GR-LIN-20





DLT-06/08M-L

Internal Air Cylinder Linear Thruster Slides | Dimensions and Technical Specifications

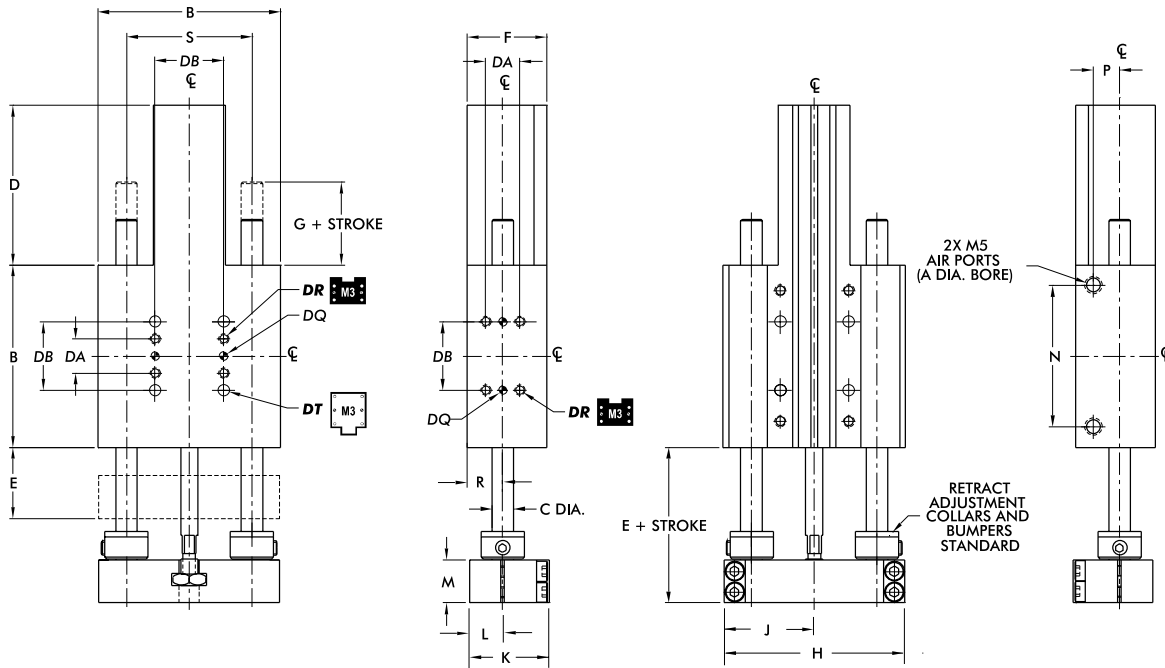

Pneumatic Accessories	Model	Part #	Qty/Unit
Cylinder Seal Kit (Buna-N)	ALL	SLKT-108	1
Cylinder Seal Kit (Viton®)		SLKT-108V	

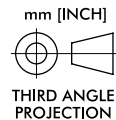
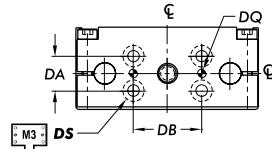

DIRECTCONNECT™ Mounting Pattern Dimensions (all sizes)					
DA	DB	DQ	DR	DS	DT
9.5 [0.375]	19.1 [0.750]	3H7 X 2 DP	M3 x 6 DP	CLR & C'BORE FOR M3	CLR & C'BORE FOR M3

Model	Bore Ø Body Size Shaft Ø			Basic Unit Dimensions												
	A	B	C	D	E	F	G	H	J	K	L	M	N	P	R	S
DLT-06M	14 [0.563]	50.8 [2.00]	6.0 [0.236]	44.4 [1.75]	19.9 [0.783]	22.4 [0.88]	16.8 [0.66]	50.3 [1.980]	25.1 [0.990]	22.2 [0.875]	9.3 [0.365]	11.9 [0.470]	39.4 [1.55]	5.4 [0.21]	9.9 [0.390]	34.93 [1.375]
DLT-08M		63.5 [2.50]	8.0 [0.315]				10.4 [0.41]	62.7 [2.470]	31.0 [1.235]				52.1 [2.05]			44.45 [1.750]

Dimensions in mm [in]

Loading Information

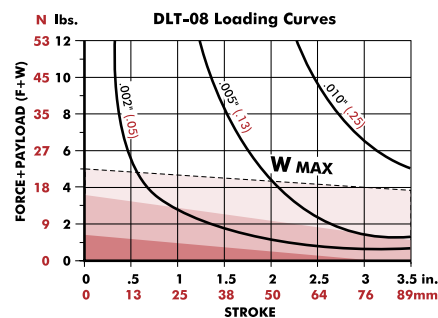
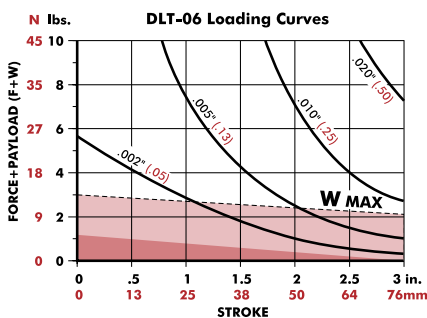

F=Externally applied force
 W=Weight of payload
 F+W=Total force
 M=Maximum moment (in-lb. or N-m)

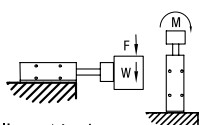

Shock Absorbers and Flow Controls are recommended for all applications

Use Double Shocks in both directions Use Single Shock in both directions Use Bumpers or Cushioned Cylinder

Shaded shock absorption ranges of horizontal payload (W) @ 80psi, flow controls fully open. For vertical applications do not exceed 1/2 of the recommended payload due to the additional acceleration effect of gravity.

Dimensions and technical information are subject to change without notice

GR-LIN-22



DLT-10/12/16M-B



Internal Air Cylinder Linear Thruster Slides | Dimensions and Technical Specifications

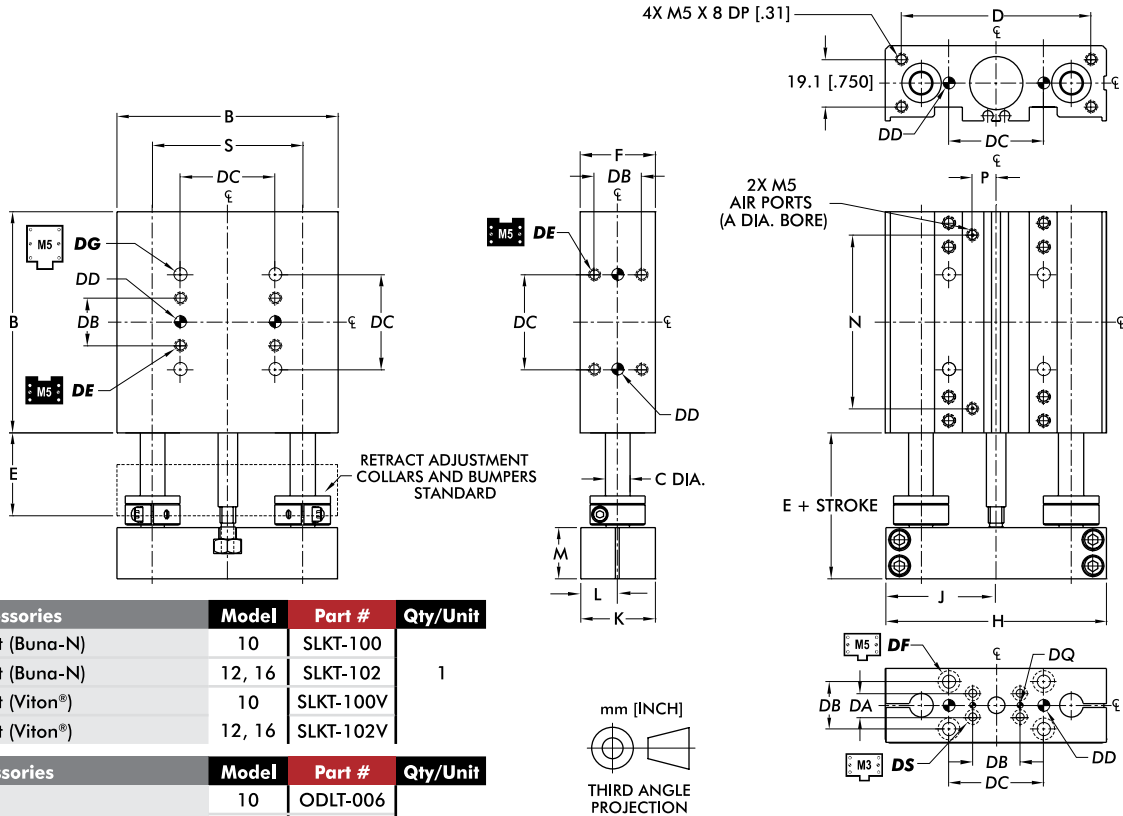

Pneumatic Accessories	Model	Part #	Qty/Unit
Cylinder Seal Kit (Buna-N)	10	SLKT-100	1
Cylinder Seal Kit (Buna-N)	12, 16	SLKT-102	
Cylinder Seal Kit (Viton®)	10	SLKT-100V	
Cylinder Seal Kit (Viton®)	12, 16	SLKT-102V	
Mounting Accessories	Model	Part #	Qty/Unit
Base Flange Kit	10	ODLT-006	1
	12	ODLT-008	
	16	ODLT-010	

DIRECTCONNECT™ Mounting Pattern Dimensions (all sizes)								
DA	DB	DC	DD	DE	DF	DG	DQ	DS
9.5 [0.375]	19.1 [0.750]	38.1 [1.500]	5mm H7 X 6 DP	M5 X 8.5 DP	CLEARANCE FOR M5		3H7 X 2 DP	CLR & C'BORE FOR M3

Model	Basic Unit Dimensions															
	Bore Ø	Body Size	Shaft Ø	A	B	C	D	E	F	H	J	K	L	M	N	P
DLB-10M	19 [0.75]	88.9 [3.50]	9.5 [0.375]	76.2 [3.000]	33.4 [1.313]	30.2 [1.19]	88.6 [3.490]	44.2 [1.740]	29.9 [1.178]	14.8 [0.584]	20.7 [0.813]	69.7 [2.75]	9.4 [0.37]	60.33 [2.375]		
DLB-12M	25 [0.98]	101.6 [4.00]	12.0 [0.472]	92.1 [3.625]		41.4 [1.63]	101.2 [3.985]	50.4 [1.985]	41.0 [1.615]	20.4 [0.802]		83.3 [3.28]		69.85 [2.750]		
DLB-16M		120.7 [4.75]	16.0 [0.630]	111.1 [4.375]		34.9 [1.375]	120.3 [4.735]	59.9 [2.360]	102.4 [4.03]	82.55 [3.250]						

Dimensions in mm [in]

Loading Information

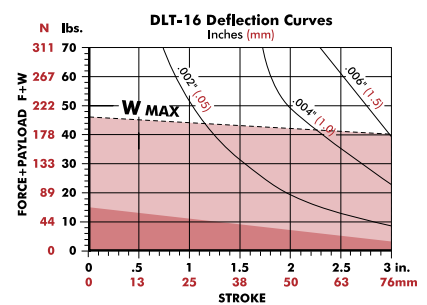
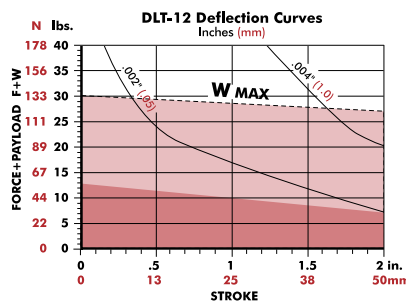
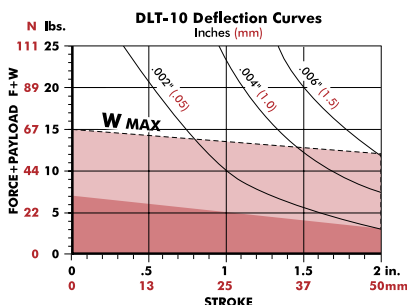

F=Externally applied force
 W=Weight of payload
 F+W=Total force
 M=Maximum moment (in-lb. or N-m)

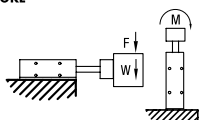

Shock Absorbers and Flow Controls are recommended for all applications

(W) in this range use **Single Shock** in retract directions

(W) in this range use **Bumpers or Cushioned Cylinder**

Shaded shock absorption ranges of horizontal payload (W) @ 80psi, flow controls fully open. For vertical applications do not exceed 1/2 of the recommended payload due to the additional acceleration effect of gravity.



GR-LIN-23

Dimensions and technical information are subject to change without notice



DLT-10/12/16M-E

Internal Air Cylinder Linear Thruster Slides | Dimensions and Technical Specifications

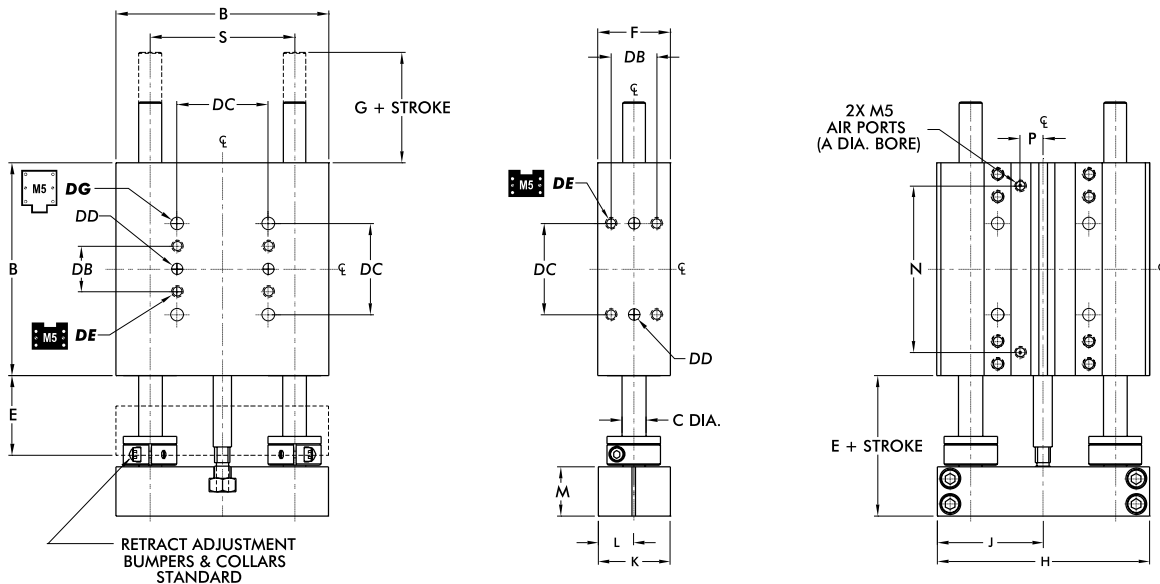

Pneumatic Accessories	Model	Part #	Qty/Unit
Cylinder Seal Kit (Buna-N)	10	SLKT-100	1
Cylinder Seal Kit (Buna-N)	12, 16	SLKT-102	
Cylinder Seal Kit (Viton®)	10	SLKT-100V	
Cylinder Seal Kit (Viton®)	12, 16	SLKT-102V	

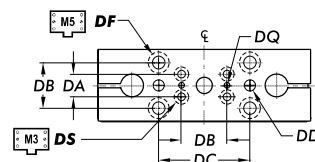

DIRECTCONNECT™ Mounting Pattern Dimensions (all sizes)									
DA	DB	DC	DD	DE	DF	DG	DQ	DS	
9.5 [0.375]	19.1 [0.750]	38.1 [1.500]	5mm H7 X 6 DP	M5 X 8.5 DP	CLEARANCE FOR M5		3H7 X 2 DP	CLR & C'BORE FOR M3	

Model	Bore Ø			Basic Unit Dimensions										
	A	B	C	E	F	G	H	J	K	L	M	N	P	S
DLB-10M	19 [3/4]	88.9 [3.50]	9.5 [0.375]	33.4 [1.313]	30.2 [1.19]	20.8 [0.82]	88.6 [3.490]	44.2 [1.740]	29.9 [1.178]	14.8 [0.584]		69.7 [2.75]		60.33 [2.375]
DLB-12M	25 [1]	101.6 [4.00]	12.0 [0.472]		41.4 [1.63]		101.2 [3.985]	50.4 [1.985]			20.7 [0.813]	83.3 [3.28]	9.4 [0.37]	69.85 [2.750]
DLB-16M		120.7 [4.75]	16.0 [0.630]	34.9 [1.375]		19.3 [0.76]	120.3 [4.735]	59.9 [2.360]	41.0 [1.615]	20.4 [0.802]		102.4 [4.03]		82.55 [3.250]

Dimensions in mm [in]

Loading Information

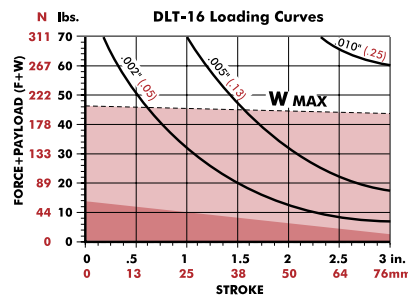
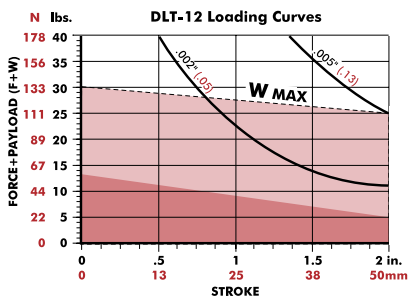
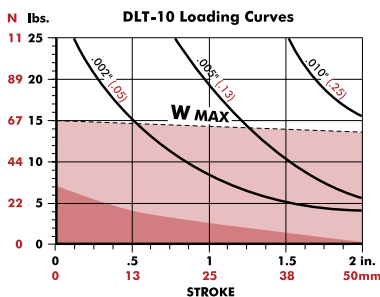

F=Externally applied force
 W=Weight of payload
 F+W=Total force
 M=Maximum moment (in-lb. or N-m)

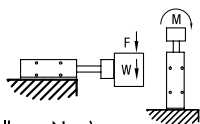

Shock Absorbers and Flow Controls are recommended for all applications

(W) in this range use **Single Shock** in retract directions (W) in this range use **Bumpers or Cushioned Cylinder**

Shaded shock absorption ranges of horizontal payload (W) @ 80psi, flow controls fully open. For vertical applications do not exceed 1/2 of the recommended payload due to the additional acceleration effect of gravity.

Dimensions and technical information are subject to change without notice

GR-LIN-24



DLT-10/12/16M-L



Internal Air Cylinder Linear Thruster Slides | Dimensions and Technical Specifications

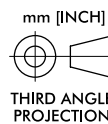
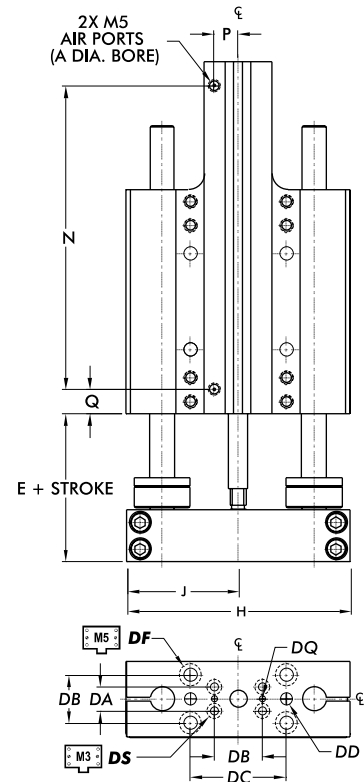
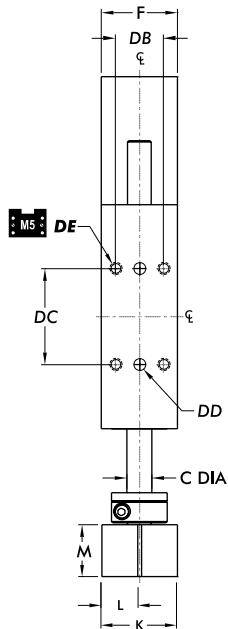
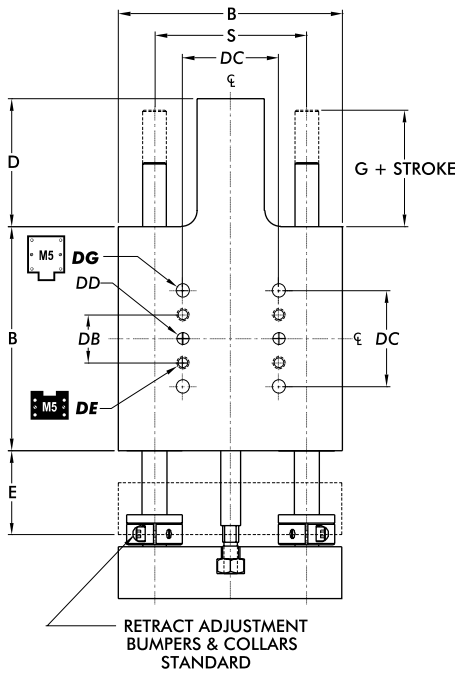

Pneumatic Accessories	Model	Part #	Qty/Unit
Cylinder Seal Kit (Buna-N)	10	SLKT-100	1
Cylinder Seal Kit (Buna-N)	12, 16	SLKT-102	
Cylinder Seal Kit (Viton®)	10	SLKT-100V	
Cylinder Seal Kit (Viton®)	12, 16	SLKT-102V	

DIRECTCONNECT™ Mounting Pattern Dimensions (all sizes)

DA	DB	DC	DD	DE	DF	DG	DQ	DS
9.5 [0.375]	19.1 [0.750]	38.1 [1.500]	5mm H7 X 6 DP	M5 X 8.5 DP	CLEARANCE FOR M5		3H7 X 2 DP	CLR & C'BORE FOR M3

Model	Basic Unit Dimensions			Basic Unit Dimensions															
	Bore Ø	Body Size	Shaft Ø	A	B	C	D	E	F	G	H	J	K	L	M	N	P	Q	S
DLB-10M	19 [3/4]	88.9 [3.50]	9.5 [0.375]	50.8 [2.00]		30.2 [1.19]		33.4 [1.313]		20.8 [0.82]	88.6 [3.490]	44.2 [1.740]	29.9 [1.178]	14.8 [0.584]		120.7 [4.75]	9.6 [0.38]	9.6 [0.38]	60.33 [2.375]
DLB-12M	25 [1]	101.6 [4.00]	12.0 [0.472]	63.5 [2.50]		41.4 [1.63]					101.2 [3.985]	50.4 [1.985]		20.7 [0.813]	146.8 [5.78]	9.4 [0.37]	9.1 [0.36]	69.85 [2.750]	
DLB-16M		120.7 [4.75]	16.0 [0.630]	69.9 [2.75]	34.9 [1.375]		19.3 [0.76]					120.3 [4.735]	59.9 [2.360]	41.0 [1.615]	20.4 [0.802]	172.2 [6.78]			82.55 [3.250]

Dimensions in mm [in]

Loading Information

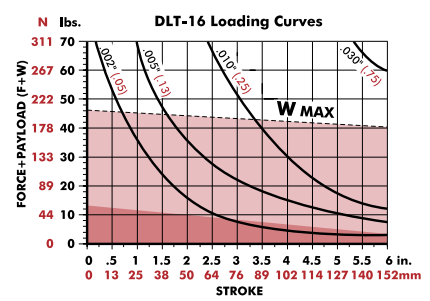
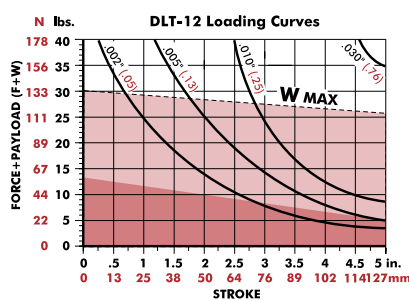
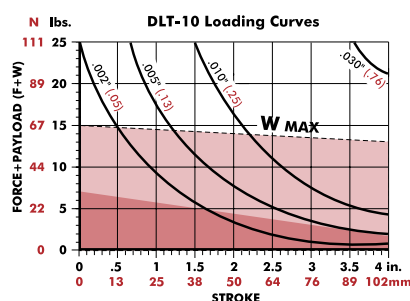

F=Externally applied force
 W=Weight of payload
 F+W=Total force
 M=Maximum moment (in-lb. or N-m)

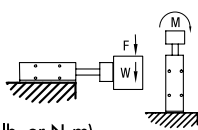

Shock Absorbers and Flow Controls are recommended for all applications

(W) in this range use **Single Shock** in retract directions

(W) in this range use **Bumpers or Cushioned Cylinder**

Shaded shock absorption ranges of horizontal payload (W) @ 80psi, flow controls fully open. For vertical applications do not exceed 1/2 of the recommended payload due to the additional acceleration effect of gravity.



GR-LIN-25

Dimensions and technical information are subject to change without notice



DLT-20/25M-B

Internal Air Cylinder Linear Thruster Slides | Dimensions and Technical Specifications

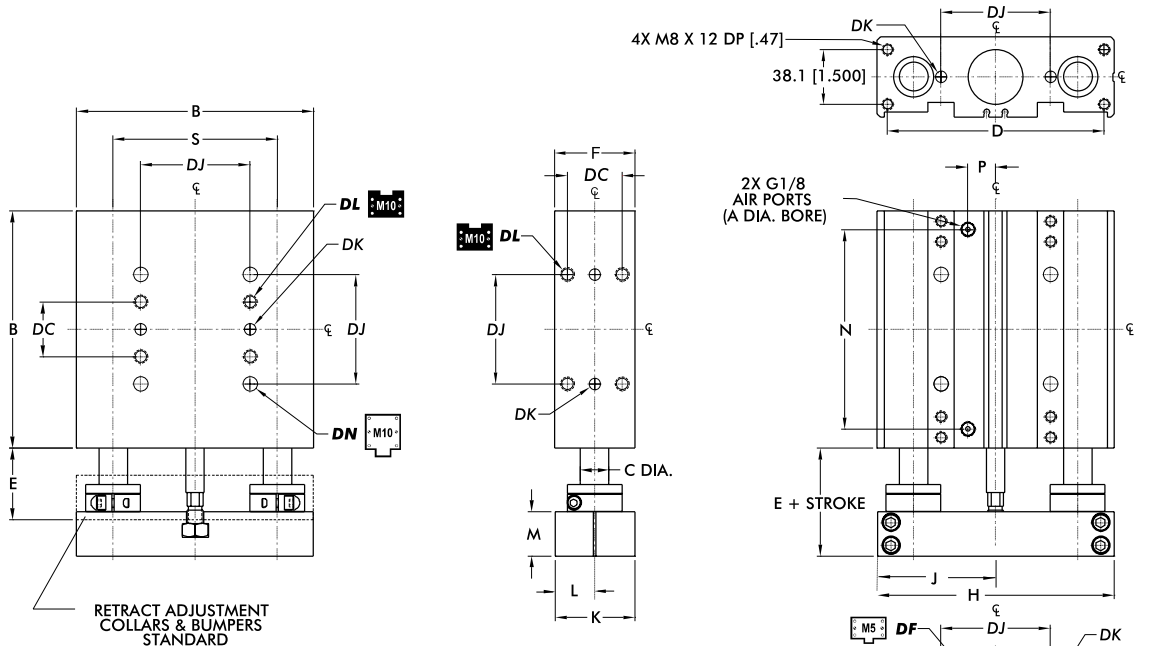

Pneumatic Accessories	Model	Part #	Qty/Unit
Cylinder Seal Kit (Buna-N)	20	SLKT-104	1
Cylinder Seal Kit (Viton®)	25	SLKT-104V	1

Mounting Accessories	Model	Part #	Qty/Unit
Base Flange Kit	20	ODLT-012	1
	25	ODLT-014	1

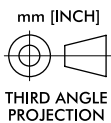

DIRECTCONNECT™ Mounting Pattern Dimensions (all sizes)									
DB	DC	DD	DF	DJ	DK	DL	DM	DN	
19.1 [0.750]	38.1 [1.500]	5mm H7 X 6 DP	CLEARANCE FOR M5	76.2 [3.000]	8mm H7 x 9.4 DP	M10 x 14.2 DP	CLR & C'BORE FOR M10		

Model	Bore Ø			Body Size			Shaft Ø			Basic Unit Dimensions						
	A	B	C	D	E	F	H	J	K	L	M	N	P	S		
DLB-20M	38 [1 1/2]	165.1 [6.50]	20 [0.787]	150.8 [5.938]	49.8 [1.960]	55.9 [2.20]	164.6 [6.480]	82.0 [3.230]	55.4 [2.180]	27.4 [1.080]	30.7 [1.210]	138.9 [5.47]	19.5 [0.77]	114.30 [4.500]		
DLB-25M		190.5 [7.50]	25 [0.984]	176.2 [6.938]	55.1 [2.170]		190.0 [7.480]	94.7 [3.730]			36.1 [1.420]	164.3 [6.47]		133.35 [5.250]		

Dimensions in mm [in]

Loading Information

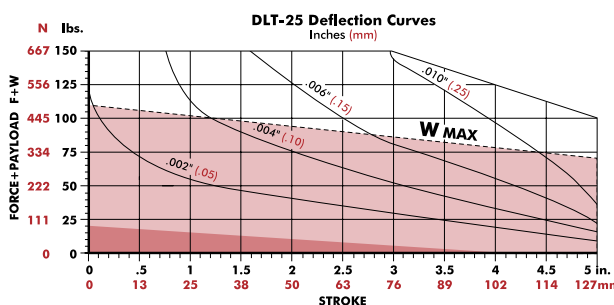
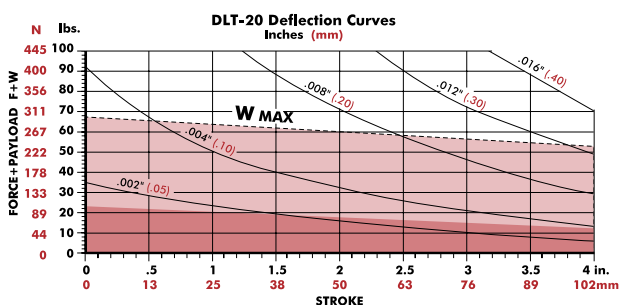

F=Externally applied force
 W=Weight of payload
 F+W=Total force
 M=Maximum moment (in-lb. or N-m)

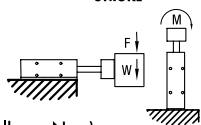

Shock Absorbers and Flow Controls are recommended for all applications

(W) in this range use **Single Shock** in retract directions (W) in this range use **Bumpers or Cushioned Cylinder**

Shaded shock absorption ranges of horizontal payload (W) @ 80psi, flow controls fully open. For vertical applications do not exceed 1/2 of the recommended payload due to the additional acceleration effect of gravity.

Dimensions and technical information are subject to change without notice

GR-LIN-26



DLT-20/25M-E



Internal Air Cylinder Linear Thruster Slides | Dimensions and Technical Specifications

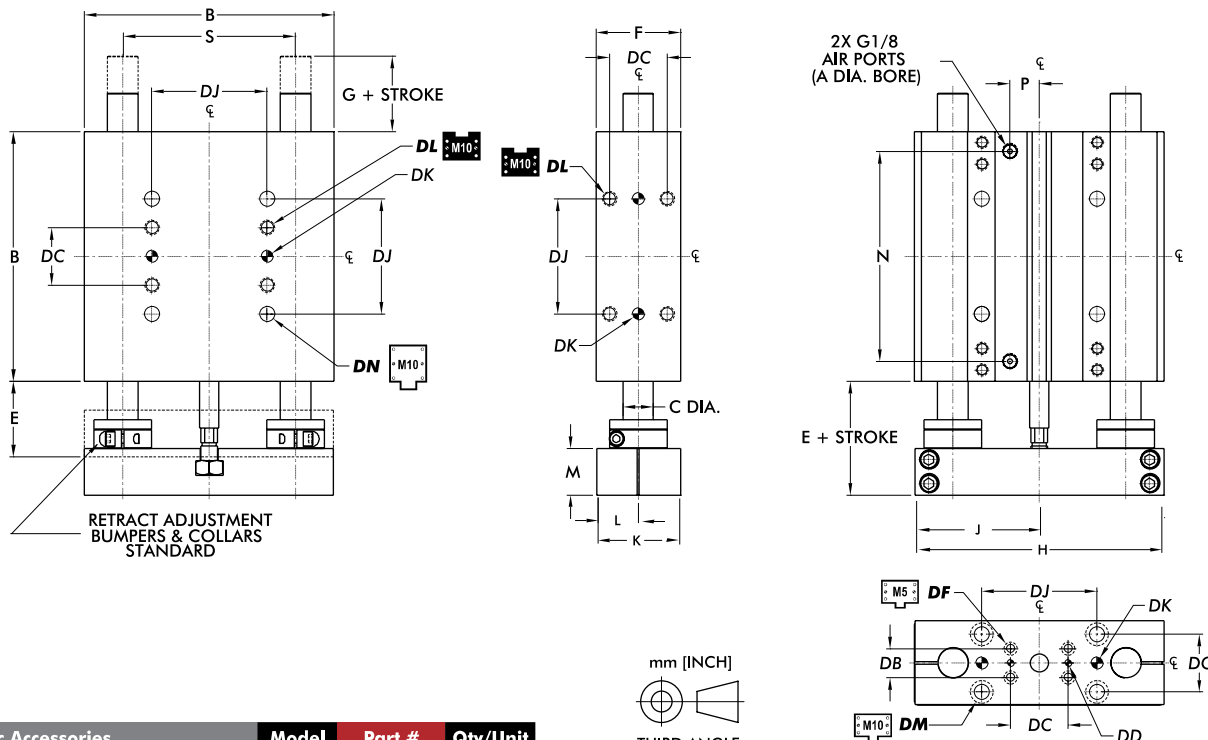

Pneumatic Accessories	Model	Part #	Qty/Unit
Cylinder Seal Kit (Buna-N)	20	SLKT-104	1
Cylinder Seal Kit (Viton®)	25	SLKT-104V	1

DIRECTCONNECT™ Mounting Pattern Dimensions (all sizes)								
DB	DC	DD	DF	DJ	DK	DL	DM	DN
19.1 [0.750]	38.1 [1.500]	5mm H7 X 6 DP	CLEARANCE FOR M5	76.2 [3.000]	8mm H7 x 9.4 DP	M10 x 14.2 DP	CLR & C'BORE FOR M10	

Model	Basic Unit Dimensions			Basic Unit Dimensions												
	Bore Ø	Body Size	Shaft Ø	A	B	C	E	F	G	H	J	K	L	M	N	P
DLT-20M	38 [1 1/2]	165.1 [6.50]	20 [0.787]	49.8 [1.960]	55.9 [2.20]	24.4 [0.960]	164.6 [6.480]	82.0 [3.230]	55.4 [2.180]	27.4 [1.080]	30.7 [1.210]	138.9 [5.47]	19.5 [0.77]	114.30 [4.300]		
DLT-25M		190.5 [7.50]	25 [0.984]	55.1 [2.170]	29.7 [1.170]	190.0 [7.480]	94.7 [3.730]	55.4 [2.180]	27.4 [1.080]	36.1 [1.420]	164.3 [6.47]	19.5 [0.77]	133.35 [5.250]			

Dimensions in mm [in]

Loading Information

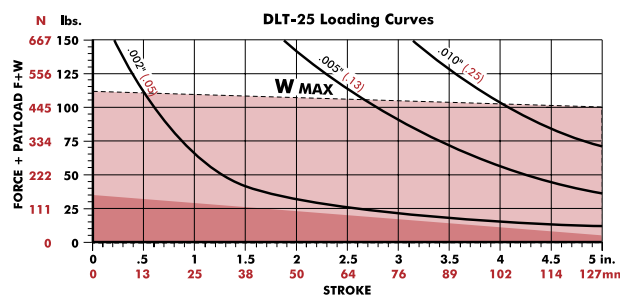
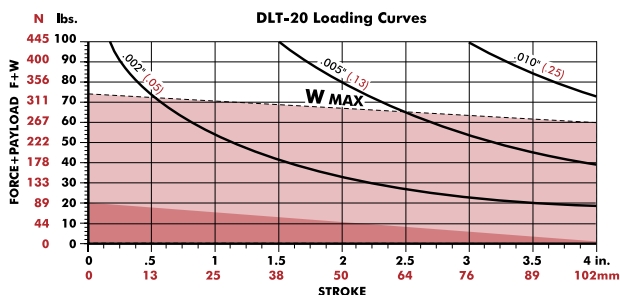

Shock Absorbers and Flow Controls are recommended for all applications

F=Externally applied force
 W=Weight of payload
 F+W=Total force
 M=Maximum moment (in-lb. or N-m)

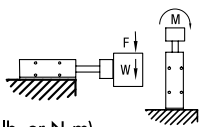

(W) in this range use **Single Shock** in retract directions

(W) in this range use **Bumpers or Cushioned Cylinder**

Shaded shock absorption ranges of horizontal payload (W) @ 80psi, flow controls fully open. For vertical applications do not exceed 1/2 of the recommended payload due to the additional acceleration effect of gravity.



GR-LIN-27

Dimensions and technical information are subject to change without notice



DLT-20/25M-L

Internal Air Cylinder Linear Thruster Slides | Dimensions and Technical Specifications

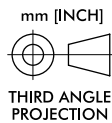
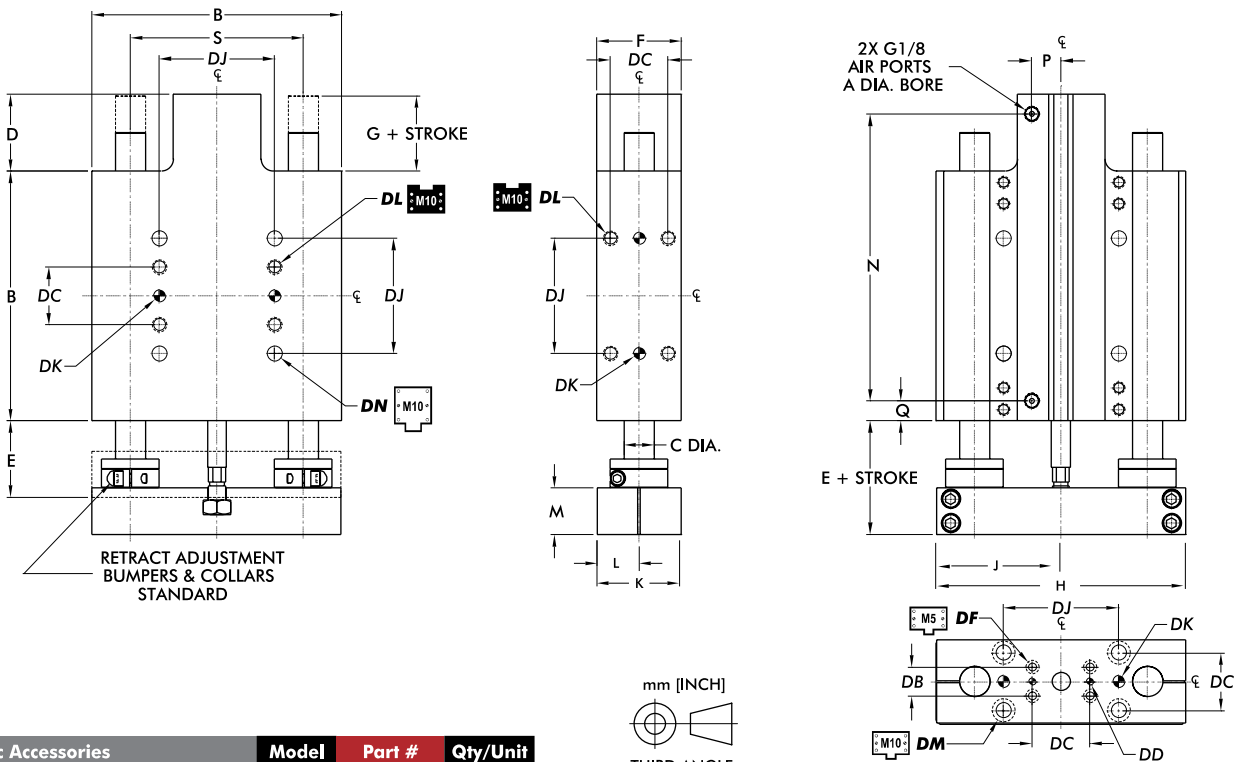

Pneumatic Accessories	Model	Part #	Qty/Unit
Cylinder Seal Kit (Buna-N)	20	SLKT-104	1
Cylinder Seal Kit (Viton®)	25	SLKT-104V	1

DIRECTCONNECT™ Mounting Pattern Dimensions (all sizes)									
DB	DC	DD	DF	DJ	DK	DL	DM	DN	
19.1 [0.750]	38.1 [1.500]	5mm H7 X 6 DP	CLEARANCE FOR M5	76.2 [3.000]	8mm H7 x 9.4 DP	M10 x 14.2 DP	CLR & C'BORE FOR M10		

Model	Bore Ø	Body Size	Shaft Ø	Basic Unit Dimensions												
				A	B	C	D	E	F	G	H	J	K	L	M	N
DLT-20M	38 [1 1/2]	165.1 [6.50]	20 [0.787]	50.8 [2.00]	49.8 [1.960]	55.9 [2.20]	24.4 [0.960]	164.6 [6.480]	82.0 [3.230]	55.4 [2.180]	27.4 [1.080]	30.7 [1.210]	189.7 [7.469]	19.4 [0.77]	13.1 [0.52]	114.30 [4.500]
DLT-25M		190.5 [7.50]	25 [0.984]		55.1 [2.170]	29.7 [1.170]	190.0 [7.480]	94.7 [3.730]	36.1 [1.420]			215.1 [8.468]	133.35 [5.250]			

Dimensions in mm [in]

Loading Information

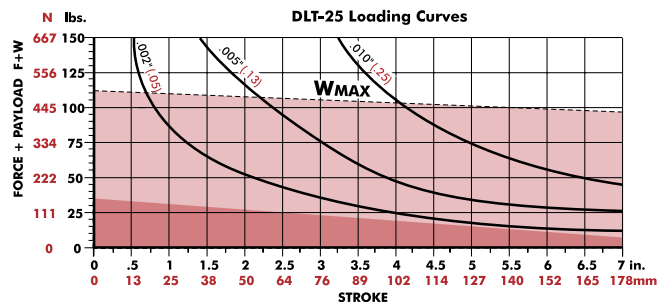
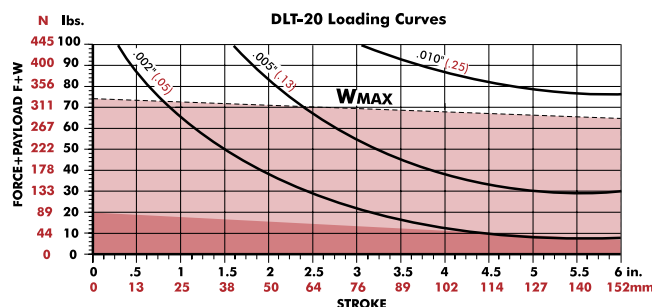

F=Externally applied force
 W=Weight of payload
 F+W=Total force
 M=Maximum moment (in-lb. or N-m)

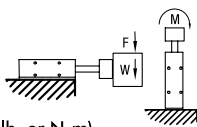

Shock Absorbers and Flow Controls are recommended for all applications

(W) in this range use **Single Shock** in retract directions (W) in this range use **Bumpers or Cushioned Cylinder**

Shaded shock absorption ranges of horizontal payload (W) @ 80psi, flow controls fully open. For vertical applications do not exceed 1/2 of the recommended payload due to the additional acceleration effect of gravity.

Dimensions and technical information are subject to change without notice

GR-LIN-28



DLT SERIES - EXTERNAL AIR CYLINDER

External Air Cylinder Linear Thruster Slides | Features and Benefits | How To Order

Features:

- Bearing system for smooth operation
- Rugged design produces very reliable long life operation
- Replaceable air cylinder with adjustable cushions
- Non-powered Thrusters use customer supplied cylinders
- Urethane bumpers, hardened pads, oil wick
- Optional telescopic airlines transfers air to tooling
- DIRECTCONNECT™ mounting pattern
- Corrosion resistant shafting for corrosive environments
- Position sensing using inductive or magneto resistive sensors

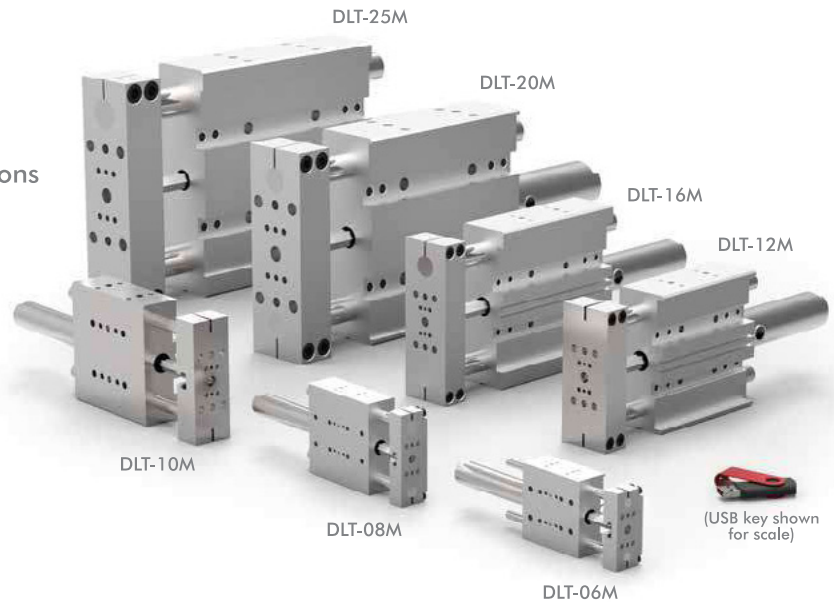

Applications:

- Machining and automation applications
- Harsh environment pick-and-place applications
- Gantry system applications

How To Order

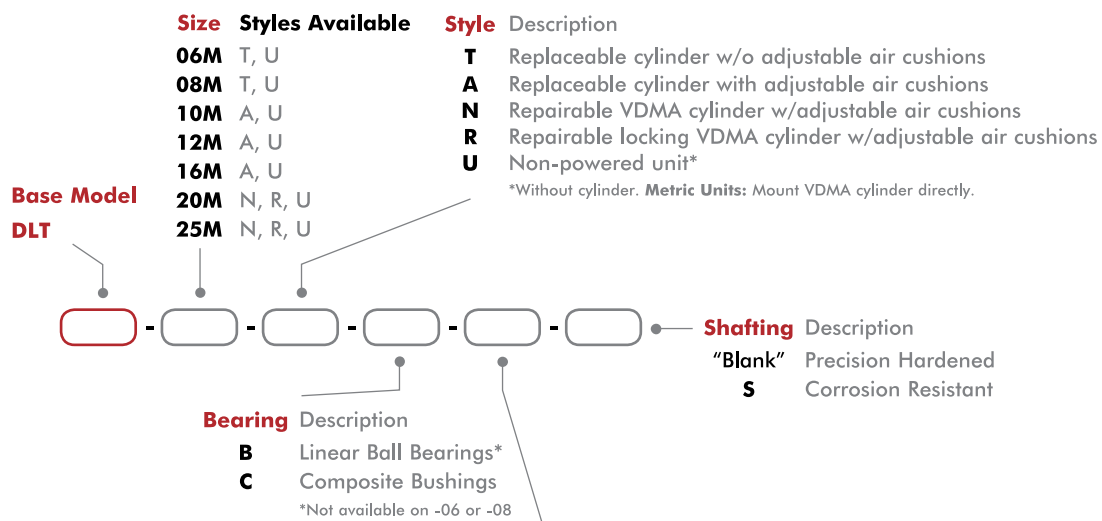

Size	Style	Stroke* Metric (mm)
DLT-06M	T, U	10, 25, 40, 50, 75, 100, 125, 160
DLT-08M	T, U	10, 25, 40, 50, 75, 100, 125, 160, 175, 200
DLT-10M	A, U	25, 50, 80, 100, 125, 160, 200, 250, 300
DLT-12M	A, U	25, 50, 80, 100, 125, 160, 200, 250, 300, 320, 360, 400
DLT-16M	A, U	25, 50, 80, 100, 125, 160, 200, 250, 300, 320, 360, 400, 500
DLT-20M	N, R, U	25, 50, 80, 100, 125, 160, 200, 250, 300, 320, 360, 400, 500
DLT-25M	N, R, U	25, 50, 80, 100, 125, 160, 200, 250, 300, 320, 360, 400, 500

*Custom strokes available. Consult factory.



GR-LIN-29

Dimensions and technical information are subject to change without notice

DLT SERIES - EXTERNAL AIR CYLINDER

External Air Cylinder Linear Thruster Slides | Accessories

Shock/Stop & Mounting Accessories	Model Numbers	Style	Part Number	Qty/Unit
Universal Mounting Kit (Stop/Shock)	06	All	OSAK-069	1-4
	08		OSAK-070	
Universal Mounting Kit (Stop/Shock/Sensor)	10		OSAK-055	
	12		OSAK-057	
	16		OSAK-059	
	20		OSAK-061	
	25		OSAK-063	
	06, 08		SHOK-030	
Shock Absorber (2 Max on -06)	10		SHOK-028	
	12, 16,		SHOK-010	
	20, 25		SHOK-029	
	06, 08		DLT-0623	
Adjustable Hard Stop	10, 12, 16, 20, 25		DLT-1023	
	06		OSAK-067	
08	OSAK-068			
10	OSAK-065			
12	OSAK-066			
16	OSAK-060			
20	OSAK-062			
25	OSAK-064			

Sensor Accessories	Model Numbers	Style	Part Number	Qty/Unit
Inductive Sensor Mounting Kit	06	T	OSMK-076	1
Inductive Sensor Mounting Kit	08		OSMK-077	
PNP Inductive Sensor with Quick Disconnect*	06, 08,	T	OISP-014	1-2
NPN Inductive Sensor with Quick Disconnect*			OISN-014	
PNP Inductive Sensor with Quick Disconnect*	10, 12, 16, 20, 25	A, N, R	OISP-011	1-2
NPN Inductive Sensor with Quick Disconnect*			OISN-011	
PNP Magneto Resistive Sensor w/Qk Disconnect*	06, 08, 10, 12, 16	T, A	OHSP-005	1-2
NPN Magneto Resistive Sensor w/Qk Disconnect*			OHSN-005	
PNP Magneto Resistive Sensor w/Qk Disconnect*	20, 25	N, R	OHSP-020	1-2
NPN Magneto Resistive Sensor w/Qk Disconnect*			OHSN-020	
Quick Disconnect 2 Meter Cable Length*	All Model	All	CABL-010	1-2
Quick Disconnect 5 Meter Cable Length*			CABL-013	
Cable Extension Cord 1M Length*	All Models	All	CABL-015	1-2
Cable Extension Cord 2M Length*			CABL-016	

Pneumatic Accessories	Model Numbers	Style	Part Number	Qty/Unit
VDMA Cylinder Mounting Kit	20, 25	U	ODLT-004	1
G1/8 Telescopic Airlines (up to 160mm)	10, 12, 16, 20, 25	All	OTAL-045	1-4
G1/8 Telescopic Airlines (up to 300mm)			OTAL-046	
G1/8 Telescopic Airlines (up to 450mm)			OTAL-047	
G1/8 Telescopic Airlines (up to 600mm)			OTAL-048	
M5 Adjustable Flow Control	06, 08		VLVF-008	1-2
G1/8 Adjustable Flow Control	10, 12, 16, 20, 25		VLVF-005	
M5 Retract Port Standoff	06, 08		PLFT-071	

* Sensor and cable sold separately.

See page GR-LIN-36 for Accessory Mounting Technical Data

Dimensions and technical information are subject to change without notice

GR-LIN-30



DLT SERIES - EXTERNAL AIR CYLINDER

External Air Cylinder Linear Thruster Slides | Technical Specifications

Specifications	Units	06	08	10	12	16	20	25
Max. Air Pressure	bar [psi]	7 [100]						
Thrust Force @ 5.5 bar [80psi]	N [lbs]	111 [20]	89 [20]	173 [35]	270 [70]	270 [70]	443 [140]	443 [140]
Weight (basic unit)	kg [lb]	0.24 [0.53]	0.40 [0.88]	1.05 [2.12]	1.64 [3.42]	2.11 [4.47]	6.3 [14.3]	8.5 [19.2]
Additional Weight per Stroke	g/mm [lbs/in]	0.88 [0.05]	1.43 [0.07]	1.2 [0.09]	2.9 [0.15]	4.2 [0.23]	7.9 [0.53]	10.7 [0.68]
Cylinder Bore Ø	mm [in]	16 [0.563]		20 [0.787]	25 [0.984]		32 [1.26]	
Shaft Ø	mm [in]	6 [0.236]	8 [0.315]	9.5 [0.375]	12 [0.472]	16 [0.630]	20 [0.787]	25 [0.984]
Max (M) Vertical Motion	Nm [in-lbs]	0.6 [5]	1.3 [10]	--	--	--	--	--
Min. Air Pressure to Release Cyl. Lock -R	bar [psi]	--	--	--	--	--	4 [60]	
Holding Force of Lock Mechanism -R	N [lbs]	--	--	--	--	--	550 [123]	



DLT-06/08M-T, U

External Air Cylinder Linear Thruster Slides | Dimensions and Technical Specifications

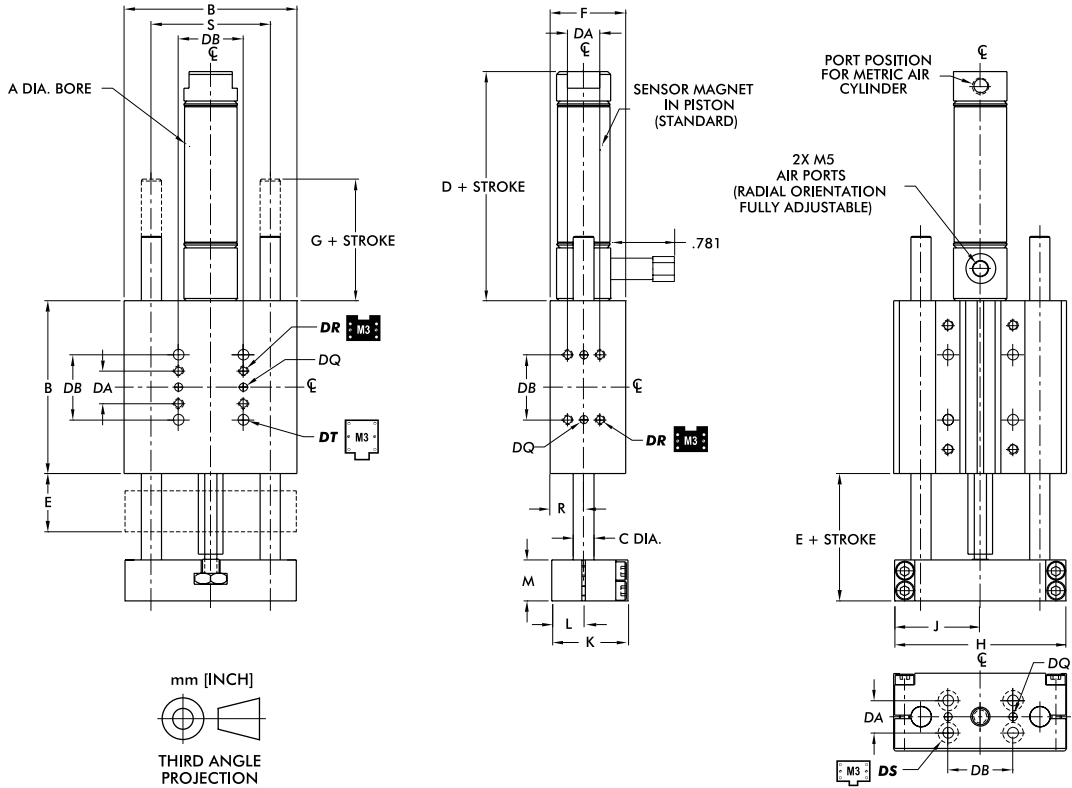

DIRECTCONNECT™ Mounting Pattern Dimensions (all sizes)					
DA	DB	DQ	DR	DS	DT
9.5 [0.375]	19.1 [0.750]	3H7 X 2 DP	M3 x 6 DP	CLR & C'BORE FOR M3	CLR & C'BORE FOR M3

Model	Bore Ø			Basic Unit Dimensions										
	A	B	C	D	E	F	G	H	J	K	L	M	R	S
DLT-06M	16 [0.63]	50.8 [2.00]	6.0 [0.236]	54.9 [2.16]	19.9 [0.783]	22.4 [0.88]	16.7 [0.66]	50.3 [1.980]	25.1 [0.990]	22.2 [0.875]	9.3 [0.365]	11.9 [0.470]	9.9 [0.390]	34.93 [1.375]
DLT-08M		63.5 [2.50]	8.0 [0.315]				10.4 [0.41]	62.7 [2.470]	31.4 [1.235]					44.45 [1.750]

Dimensions in mm [in]

Loading Information

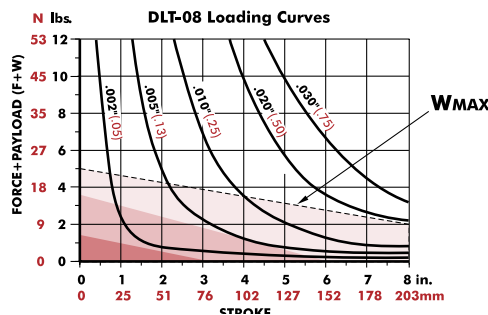
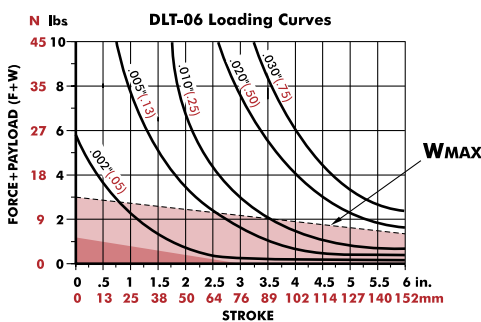

F=Externally applied force
 W=Weight of payload
 F+W=Total force
 M=Maximum moment (in-lb. or N-m)

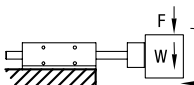

Shock Absorbers and Flow Controls are recommended for all applications

Use Double Shocks in both directions Use Single Shock in both directions Use Bumpers or Cushioned Cylinder

Shaded shock absorption ranges of horizontal payload (W) @ 80psi, flow controls fully open. For vertical applications do not exceed 1/2 of the recommended payload due to the additional acceleration effect of gravity.

Dimensions and technical information are subject to change without notice

GR-LIN-32



DLT-10/12/16M-A, U



External Air Cylinder Linear Thruster Slides | Dimensions and Technical Specifications

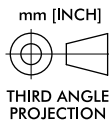
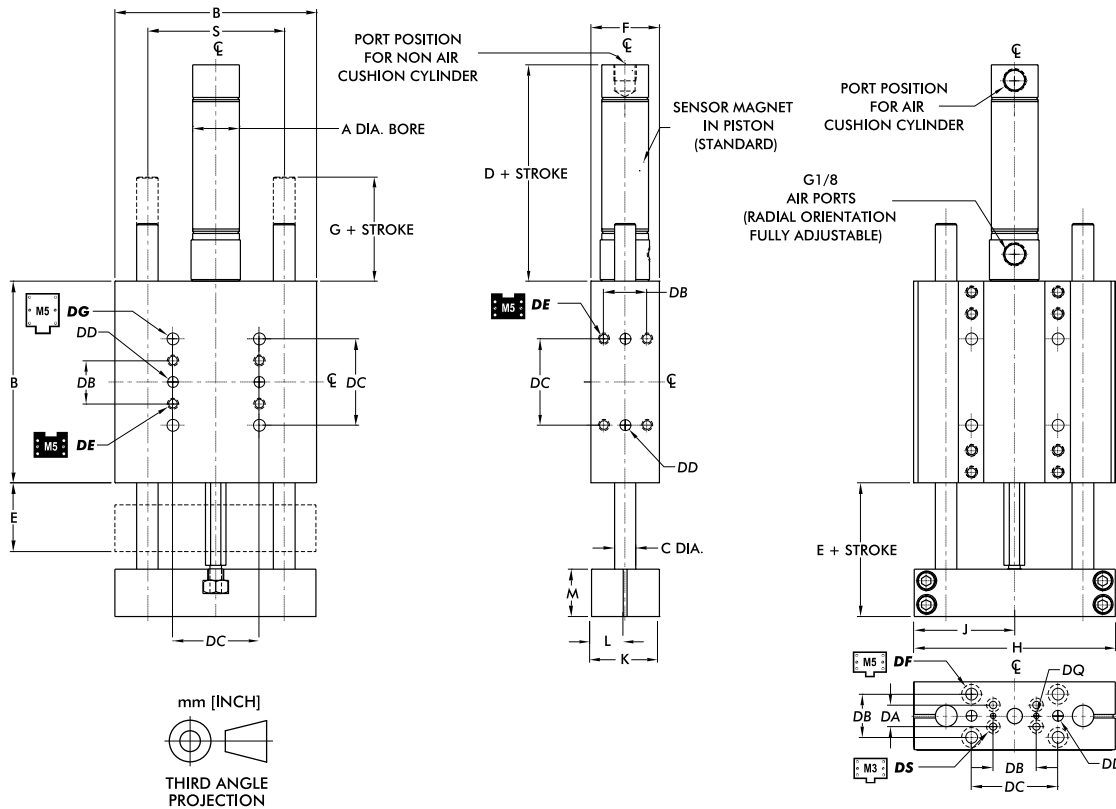

DIRECTCONNECT™ Mounting Pattern Dimensions (all sizes)

DA	DB	DC	DD	DE	DF	DG	DQ	DS
9.5 [0.375]	19.1 [0.750]	38.1 [1.500]	5mm H7 X 6 DP	M5 X 8.5 DP	CLEARANCE FOR M5		3H7 X 2 DP	CLR & C'BORE FOR M3

Model	Bore Ø Body Size Shaft Ø			Basic Unit Dimensions									
	A	B	C	D	E	F	G	H	J	K	L	M	S
DLB-10M	20 [3/4]	88.9 [3.50]	9.5 [0.375]	88.0 [2.91]	33.4 [1.313]	30.2 [1.19]	20.8 [0.82]	88.6 [3.490]	44.2 [1.740]	29.9 [1.178]	14.8 [0.584]	20.7 [0.813]	60.33 [2.375]
DLB-12M	25 [1]	101.6 [4.00]	12.0 [0.472]	91.5 [2.88]		41.4 [1.63]		101.2 [3.985]	50.4 [1.985]	41.0 [1.615]	20.4 [0.802]		69.85 [2.750]
DLB-16M			120.7 [4.75]	16.0 [0.630]		34.9 [1.375]	19.3 [0.76]	120.3 [4.735]	59.9 [2.360]		82.55 [3.250]		

Dimensions in mm [in]

Loading Information

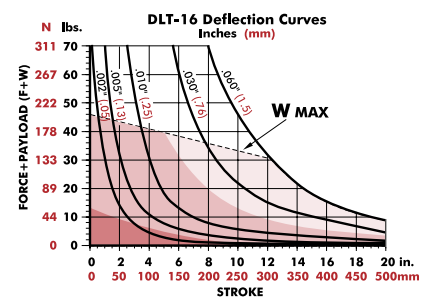
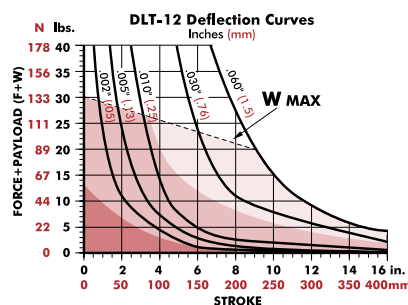
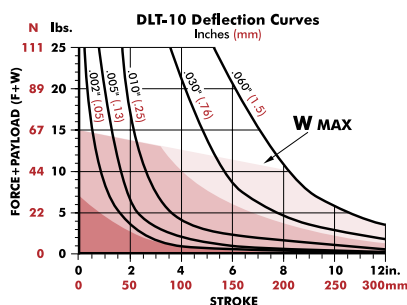

F=Externally applied force
 W=Weight of payload
 F+W=Total force
 M=Maximum moment (in-lb. or N-m)

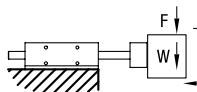

Shock Absorbers and Flow Controls are recommended for all applications

Use Double Shocks in both directions Use Single Shock in both directions Use Bumpers or Cushioned Cylinder

Shaded shock absorption ranges of horizontal payload (W) @ 80psi, flow controls fully open. For vertical applications do not exceed 1/2 of the recommended payload due to the additional acceleration effect of gravity.



GR-LIN-33

Dimensions and technical information are subject to change without notice



DLT-20/25M-A, R, U

External Air Cylinder Linear Thruster Slides | Dimensions and Technical Specifications

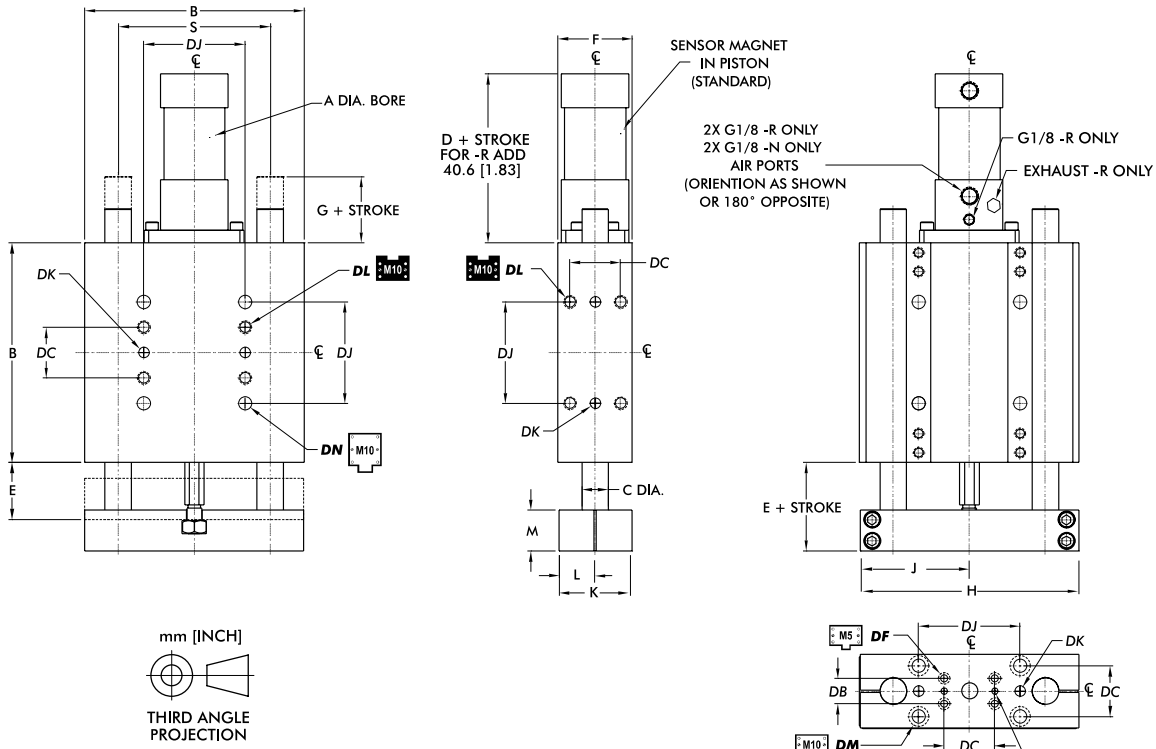

DIRECTCONNECT™ Mounting Pattern Dimensions (all sizes)

DB	DC	DD	DF	DJ	DK	DL	DM	DN
19.1 [0.750]	38.1 [1.500]	5mm H7 X 6 DP	CLEARANCE FOR M5	76.2 [3.000]	8mm H7 x 9.4 DP	M10 x 14.2 DP	CLR & C'BORE FOR M10	

Model	Basic Unit Dimensions			Basic Unit Dimensions											
	Bore Ø	Body Ø	Shaft Ø	A	B	C	D	E	F	G	H	J	K	L	M
DLB-20M	32 [1 1/2]	165.1 [6.50]	20 [0.787]	107.7 [4.01]	49.8 [1.960]	55.9 [2.20]	24.4 [0.960]	164.6 [6.480]	82.0 [3.230]	55.4 [2.180]	27.4 [1.080]	30.7 [1.210]	114.30 [4.500]		
DLB-25M		190.5 [7.50]	25 [0.984]		55.1 [2.170]		29.7 [1.170]	190.0 [7.480]	94.7 [3.730]					36.1 [1.420]	133.35 [5.250]

Dimensions in mm [in]

Loading Information

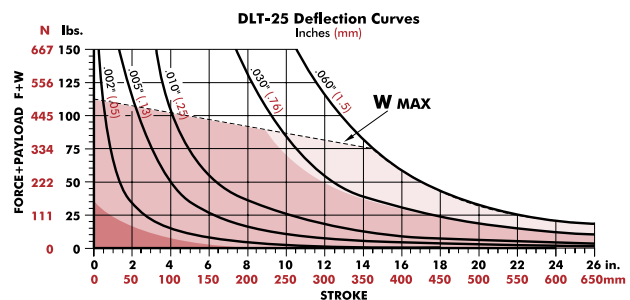
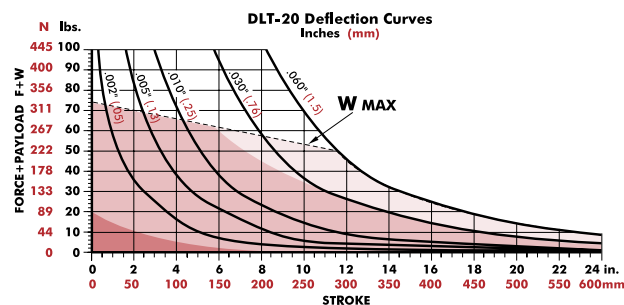

F=Externally applied force
 W=Weight of payload
 F+W=Total force
 M=Maximum moment (in-lb. or N-m)

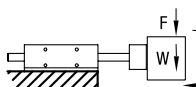

Shock Absorbers and Flow Controls are recommended for all applications

Use Double Shocks in both directions Use Single Shock in both directions Use Bumpers or Cushioned Cylinder

Shaded shock absorption ranges of horizontal payload (W) @ 80psi, flow controls fully open. For vertical applications do not exceed 1/2 of the recommended payload due to the additional acceleration effect of gravity.

Dimensions and technical information are subject to change without notice

GR-LIN-34



DLM SERIES

Miniature Rail Thruster Slide | Features and Benefits | How To Order

Features:

- Compact high reliability bearing design
- Excellent part position repeatability
- Double bearings -**D** for longer strokes, greater load and moment capacity
- Internal Delrin® extend and retract stops -**P** for increased repeatability
- Sense up to 8 positions with 4 adjustable magneto resistive sensors
- Multiple tapped air ports on each side, rear and bottom of body
- Thru-body mounting and DIRECTCONNECT™ thru tapped and dowel mounting, on tool plate and body
- Viton® seals for operation in high temperature environments

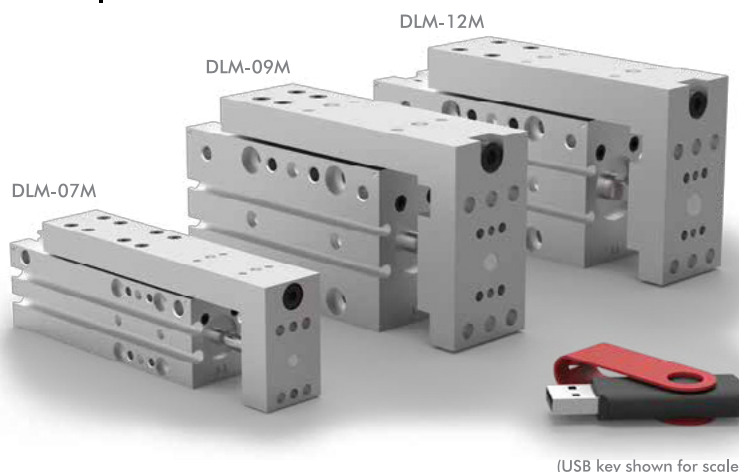

(USB key shown for scale)

Applications:

- Precision applications
- Small parts handling

How To Order

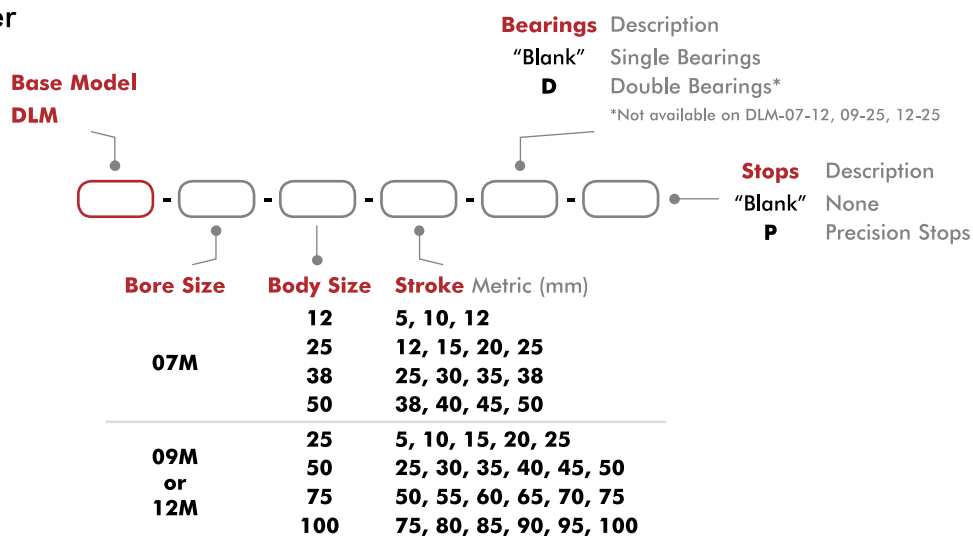

Accessories

Sensor Accessories	Model Numbers	Part Number	Qty/Unit
PNP Magneto Resistive Sensor Short Barrel (with Qk. Disc.)*	All Models	OHSP-017	1-4
NPN Magneto Resistive Sensor Short Barrel (with Qk. Disc.)*	All Models	OHSN-017	1-4
PNP Magneto Resistive Sensor 90° Barrel (with Qk. Disc.)*	All Models	OHSP-011	1-4
NPN Magneto Resistive Sensor 90° Barrel (with Qk. Disc.)*	All Models	OHSN-011	1-4
Quick Disconnect 2 Meter Cable Length*	All Models	CABL-010	1-4
Quick Disconnect 5 Meter Cable Length*	All Models	CABL-013	1-4

Pneumatic Accessories	Model Numbers	Part Number	Qty/Unit
Adjustable Flow Control	All Models	VLFL-008	1-2
Seal Kits	See Datasheets		1

*Sensor and cable sold separately.



GR-LIN-37

Dimensions and technical information are subject to change without notice

DLM SERIES

Miniature Rail Thruster Slide | Technical Specifications

Specifications	Units	DLM-07M-12	DLM-07M-25	DLM-07M-38	DLM-07M-50
Thrust Force F @ 7 bar [100 psi]	N [lbs]	66 [15]			
Max. Stroke	mm [in]	12 [0.50]	25 [1.00]	38 [1.50]	50 [2.00]
Stroke Reduction (return)	mm [in]	5 [0.19]			
Weight	kg [lbs]	0.13 [0.28]	0.16 [0.35]	0.20 [0.43]	0.23 [0.50]
Max. Payload W	kg [lbs]	0.45 [1.0]			
Max. Payload W (-P option)	kg [lbs]	0.23 [0.5]			
Cylinder Bore \varnothing	mm [in]	0.11 [0.437]			
Temperature Range	°C [°F]	-35°~80° [-30°~180°]			
Actuation (per 25mm of travel)	sec	0.07			
Linear Accuracy (per 25mm of travel)	mm [in]	±0.005 [±0.0001]			
Repeatability (-P option)	mm [in]	±0.08 [±0.003]			
Pressure Range	bar [psi]	1.4-7 [20-100]			
Valve to Actuate Double Acting		4-way, 2-position			

Specifications	Units	DLM-09M-25	DLM-09M-50	DLM-09M-75	DLM-09M-100
Thrust Force F @ 7 bar [100 psi]	N [lbs]	138 N [31 lbs]			
Max. Stroke	mm [in]	25 [1.00]	50 [2.00]	75 [3.00]	100 [4.00]
Stroke Reduction (return)	mm [in]	5 [0.19]			
Weight	kg [lbs]	0.49 [1.08]	0.64 [1.41]	0.81 [1.78]	0.97 [2.13]
Max. Payload W	kg [lbs]	0.90 [2.0]			
Max. Payload W (-P option)	kg [lbs]	0.45 [1.0]			
Cylinder Bore \varnothing	mm [in]	16 [0.630]			
Temperature Range	°C [°F]	-35°~80° [-30°~180°]			
Actuation (per 25mm of travel)	sec	0.10			
Linear Accuracy (per 25mm of travel)	mm [in]	±0.005 [±0.0001]			
Repeatability (-P option)	mm [in]	±0.08 [±0.003]			
Pressure Range	bar [psi]	1.4-7 [20-100]			
Valve to Actuate Double Acting		4-way, 2-position			

Specifications	Units	DLM-12M-25	DLM-12M-50	DLM-12M-75	DLM-12M-100
Thrust Force F @ 7 bar [100 psi]	N [lbs]	230 [51]			
Max. Stroke	mm [in]	25 [1.00]	50 [2.00]	75 [3.00]	100 [4.00]
Stroke Reduction (return)	mm [in]	5 [0.19]			
Weight	kg [lbs]	0.54 [1.18]	0.65 [1.43]	1.82 [1.80]	1.02 [2.25]
Max. Payload W	kg [lbs]	1.81 [4.0]			
Max. Payload W (-P option)	kg [lbs]	0.90 [2.0]			
Cylinder Bore \varnothing	mm [in]	22 [0.813]			
Temperature Range	°C [°F]	-35°~80° [-30°~180°]			
Actuation (per 25mm of travel)	sec	0.14			
Linear Accuracy (per 25mm of travel)	mm [in]	±0.005 [±0.0001]			
Repeatability (-P option)	mm [in]	±0.08 [±0.003]			
Pressure Range	bar [psi]	1.4-7 [20-100]			
Valve to Actuate Double Acting		4-way, 2-position			

Dimensions and technical information are subject to change without notice

GR-LIN-38



DLM-07M



Miniature Rail Thruster Slide | Dimensions and Technical Specifications

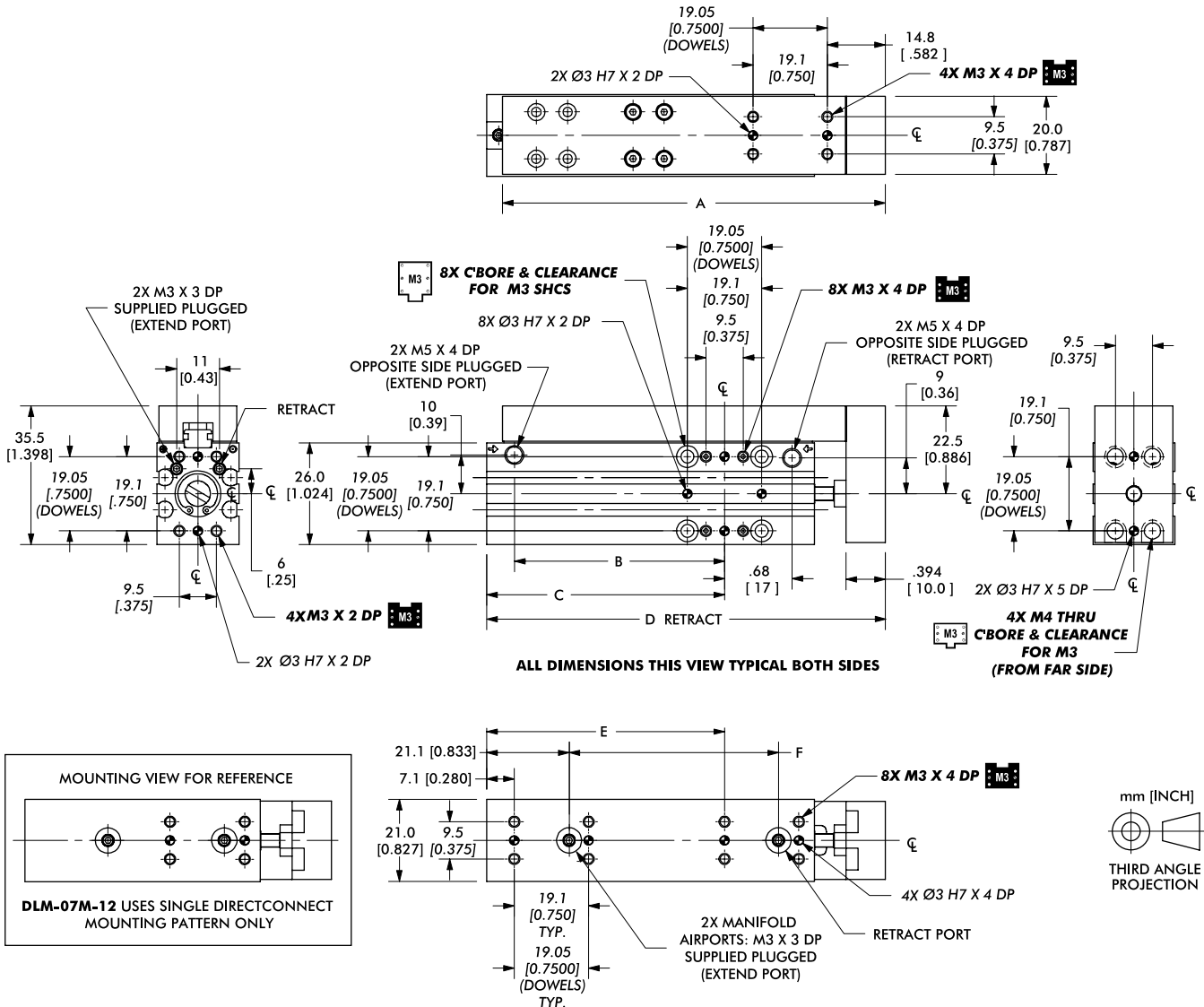

Seal Repair Kits	Order #
Buna-N Seal Repair Kit	SLKT-236
Manifold Seal Repair Kit	SLKT-239

Model	A	B	C	D	E	F	L (single bearing)	L (double bearing)
DLM-07M-12	66.0 [2.599]	30 [1.18]	37.0 [1.456]	78 [3.08]	37.0 [1.456]	29.6 [1.167]	53 [2.10]	--
DLM-07M-25	98.0 [3.859]	54 [2.12]	61.0 [2.401]	102 [4.02]	60.9 [2.401]	53.6 [2.112]	61 [2.39]	73 [2.87]
DLM-07M-38	111.0 [4.370]	67 [2.63]	74.0 [2.913]	115 [4.53]	74.0 [2.913]	66.6 [2.624]	74 [2.90]	86 [3.38]
DLM-07M-50	123.0 [4.843]	79 [3.10]	86.0 [3.385]	127 [5.00]	86.0 [3.385]	78.6 [3.096]	86 [3.37]	98 [3.86]

Dimensions in mm [in]

Loading Information

Forces shown for single bearing units. Values 2X for double bearings -D option.

DLM-07	Static
Maximum Tensile T	490 N [110 lbs]
Maximum Compressive C	490 N [110 lbs]
Maximum Moment M_x	5.1 Nm [45 in-lbs]
Maximum Moment M_y	3.2 Nm [28 in-lbs]
Maximum Payload W	3.2 Nm [28 in-lbs]
Distance to Bearing Centerline	L (see chart above)

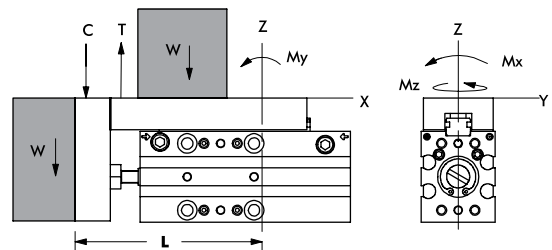

Flow Controls are recommended for all applications



GR-LIN-39

Dimensions and technical information are subject to change without notice



Miniature Rail Thruster Slide | Dimensions and Technical Specifications

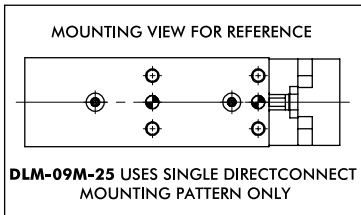
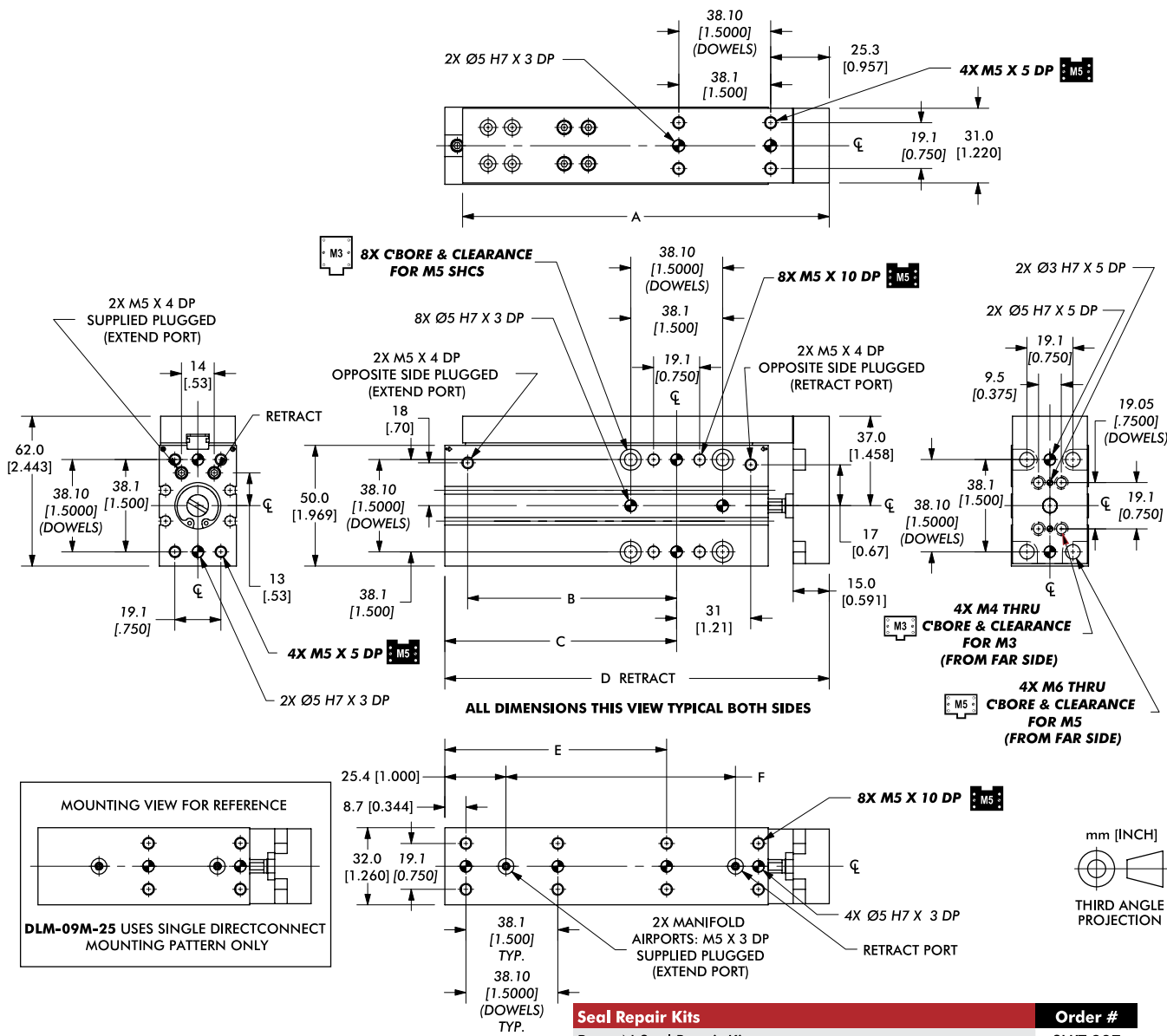

Seal Repair Kits	Order #
Buna-N Seal Repair Kit	SLKT-237
Manifold Seal Repair Kit	SLKT-240

Model	A	B	C	D	E	F	L (single bearing)	L (double bearing)
DLM-09M-25	102.0 [4.016]	41 [1.60]	50.1 [1.973]	113 [4.46]	45.9 [1.809]	49.1 [1.934]	86 [3.40]	--
DLM-09M-50	152.0 [5.985]	87 [3.41]	96.1 [3.784]	159 [6.27]	91.9 [3.620]	95.1 [3.745]	105 [4.13]	121 [4.75]
DLM-09M-75	173.0 [6.811]	112 [4.39]	121.1 [4.768]	184 [7.26]	116.9 [4.604]	120.1 [4.729]	126 [4.95]	142 [5.58]
DLM-09M-100	202.0 [7.953]	137 [5.38]	146.1 [5.752]	209 [8.24]	138.9 [5.557]	145.1 [5.713]	155 [6.10]	171 [6.72]

Dimensions in mm [in]

Loading Information

Forces shown for single bearing units. Values 2X for double bearings -D option.

DLM-09	Static
Maximum Tensile T	735 N [165 lbs]
Maximum Compressive C	735 N [165 lbs]
Maximum Moment M_x	9.6 Nm [84 in-lbs]
Maximum Moment M_y	6.4 Nm [56 in-lbs]
Maximum Payload W	6.4 Nm [56 in-lbs]
Distance to Bearing Centerline	L (see chart above)

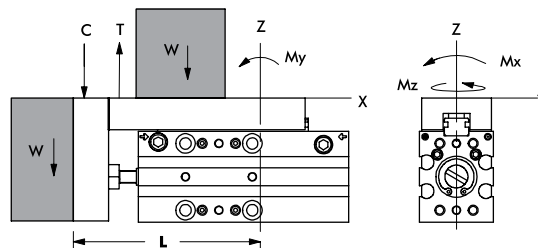

Flow Controls are recommended for all applications

Dimensions and technical information are subject to change without notice

GR-LIN-40



DLM-12M



Miniature Rail Thruster Slide | Dimensions and Technical Specifications

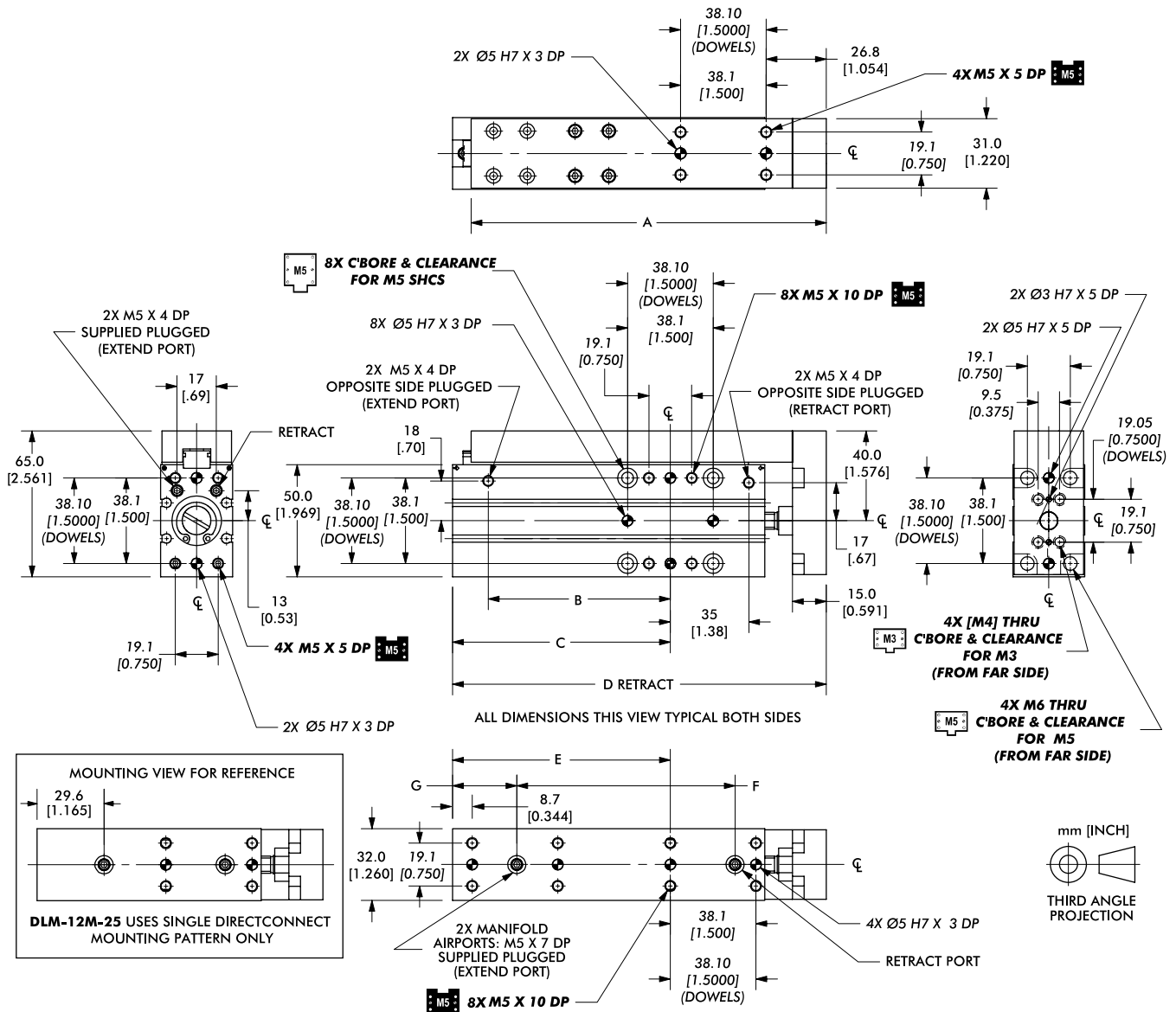

Seal Repair Kits	Order #
Buna-N Seal Repair Kit	SLKT-238
Manifold Seal Repair Kit	SLKT-240

Model	A	B	C	D	E	F	G	L (single bearing)	L (double bearing)
DLM-12M-25	105.0 [4.134]	41 [1.62]	56.9 [2.242]	126 [4.97]	56.9 [2.242]	53.5 [2.108]	29.6 [1.165]	88 [3.45]	--
DLM-12M-50	158.0 [6.221]	81 [3.19]	96.9 [3.816]	166 [6.55]	96.9 [3.816]	97.1 [3.824]		104 [4.10]	122 [4.82]
DLM-12M-75	186.0 [7.323]	108 [4.25]	123.9 [4.879]	193 [7.61]	123.9 [4.879]	124.1 [4.887]	28.6 [1.125]	132 [5.21]	150 [5.92]
DLM-12M-100	208.0 [8.189]	133 [5.24]	148.9 [5.864]	218 [8.60]	148.9 [5.864]	149.1 [5.872]		154 [6.07]	172 [6.79]

Dimensions in mm [in]

Loading Information

Forces shown for single bearing units. Values 2X for double bearings -D option.

DLM-12M	Static
Maximum Tensile T	1214 N [273 lbs]
Maximum Compressive C	1214 N [273 lbs]
Maximum Moment M_x	20.6 Nm [182 in-lbs]
Maximum Moment M_y	11.8 Nm [104 in-lbs]
Maximum Payload W	11.8 Nm [104 in-lbs]
Distance to Bearing Centerline	L (see chart above)

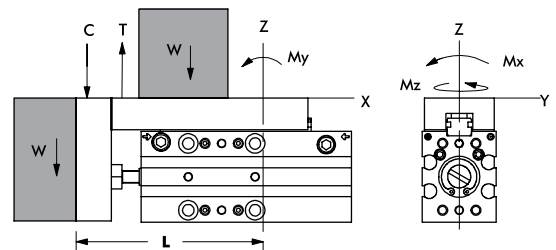

Flow Controls are recommended for all applications



GR-LIN-41

Dimensions and technical information are subject to change without notice

MPS SERIES

Miniature Rail Thruster Slide | Features and Benefits | How To Order

Features:

- Compact high reliability bearing design
- Excellent part position repeatability
- Zero side play with patented preloaded "Dual-V" roller bearings
- Adjustable extend/retract hard stops
- Two Position sensing with hall effect sensors
- Viton® seals for operation in high temperature environments

Applications:

- Precision applications
- Small parts handling
- OEM packaging machines



How To Order

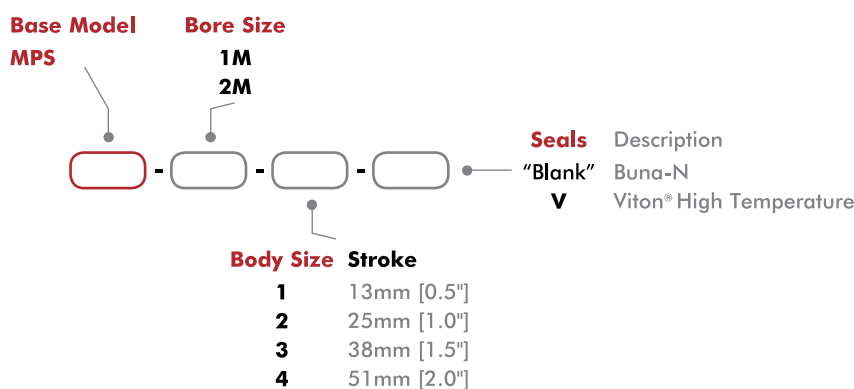

Accessories

Sensor Accessories	Model Numbers	Part Number	Qty/Unit
Magneto Resistive Sensor with Quick. Disconnect*	All Models	OHSN-006	1-2
Magneto Resistive Sensor with Quick. Disconnect*		OHSP-006	
Quick Disconnect 2 Meter Cable Length*		CABL-010	
Quick Disconnect 5 Meter Cable Length*		CABL-013	
Pneumatic Accessories	Model Numbers	Part Number	Qty/Unit
M5 Adjustable Flow Control	All Models	VLVF-008	1-2
M2.5 Barbed Fitting		PLFT-005	2
Seal Kit (Buna-N)	-1M	SLKT-090	1
Seal Kit (Viton®)	-1M	SLKT-090V	
Seal Kit (Buna-N)	-2M	SLKT-091	
Seal Kit (Viton®)	-2M	SLKT-091V	

* Sensor and cable sold separately.



GR-LIN-43

Dimensions and technical information are subject to change without notice

MPS SERIES

Miniature Rail Thruster Slide | Technical Specifications

Specifications	Units	1M-1	1M-2	1M-3	1M-4
Thrust Force F @ 7 bar [100 psi]	N [lbs]	67 [15]			
Max. Stroke	mm [in]	13 [0.50]	25 [1.00]	38 [1.50]	51 [2.00]
Stroke Adjustability (each end)	mm [in]	3 [0.12]		6 [0.25]	
Weight	kg [lb]	0.08 [0.18]	0.10 [0.22]	0.13 [0.28]	0.14 [0.32]
Max. Payload W	kg [lb]	0.14 [0.30]	0.32 [0.70]	0.45 [1.00]	0.59 [1.30]
Pressure Range	bar [psi]	1.5-7 [20-100]			
Cylinder Bore Ø	mm [in]	11.1 [0.438]			
Temperature Range (Buna-N seals)	°C [°F]	-35°~80° [-30°~180°]			
Temperature Range (Viton® seals)	°C [°F]	-30°~120° [-20°~250°]			
Actuation	sec	0.10	0.11	0.13	0.14
Linear Accuracy (per 25mm of travel)	mm [in]	±0.003 [±0.0001]			
Repeatability (-P option)	mm [in]	±0.03 [±0.010]			
Valve to Actuate Double Acting		4-way, 2-position			

Specifications	Units	2M-1	2M-2	2M-3	2M-4
Thrust Force F @ 7 bar [100 psi]	N [lbs]	196 [44]			
Max. Stroke	mm [in]	13 [0.50]	25 [1.00]	38 [1.50]	51 [2.00]
Stroke Adjustability (each end)	mm [in]	3 [0.12]		6 [0.25]	
Weight	kg [lb]	0.12 [0.26]	0.14 [0.32]	0.18 [0.40]	0.21 [0.46]
Max. Payload W	kg [lb]	0.23 [0.50]	0.45 [1.00]	0.91 [2.00]	1.36 [3.00]
Pressure Range	bar [psi]	1.5-7 [20-100]			
Cylinder Bore Ø	mm [in]	19.1 [0.750]			
Temperature Range (Buna-N seals)	°C [°F]	-35°~80° [-30°~180°]			
Temperature Range (Viton® seals)	°C [°F]	-30°~120° [-20°~250°]			
Actuation	sec	0.12	0.16	0.19	0.24
Linear Accuracy (per 25mm of travel)	mm [in]	±0.003 [±0.0001]			
Repeatability (-P option)	mm [in]	±0.03 [±0.010]			
Valve to Actuate Double Acting		4-way, 2-position			

MPS-1M

Miniature Rail Thruster Slide | Dimensions and Technical Specifications

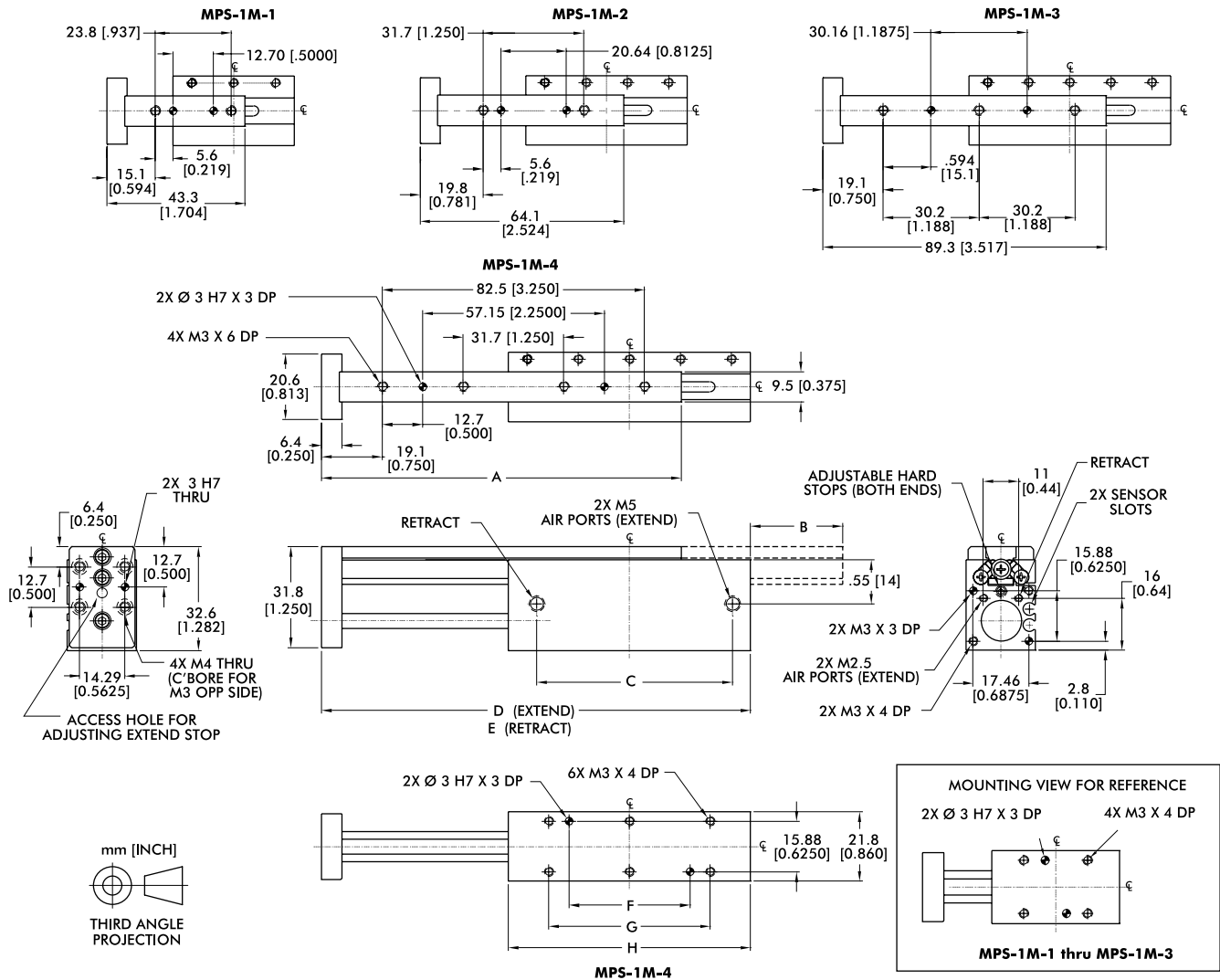

Model	A	B	C	D	E	F	G	H
MPS-1M-1	43.3 [1.704]	--	23 [0.92]	59 [2.31]	46 [1.81]	6.35 [0.2500]	19.1 [0.750]	38.1 [1.500]
MPS-1M-2	64.1 [2.524]	5.4 [0.211]	36 [1.43]	84 [3.31]	58 [2.31]	19.05 [0.7500]	31.8 [1.250]	50.8 [2.000]
MPS-1M-3	89.3 [3.517]	17.9 [0.704]	49 [1.93]	110 [4.31]	71 [2.81]	25.40 [1.0000]	38.1 [1.500]	63.5 [2.500]
MPS-1M-4	113.1 [4.454]	29.0 [1.141]	62 [2.43]	135 [5.31]	84 [3.31]	38.10 [1.5000]	50.8 [2.000]	76.2 [3.000]

Dimensions in mm [in]

Loading Information

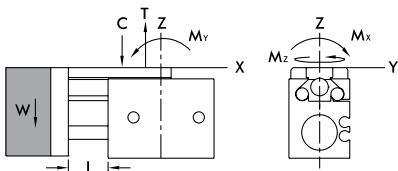

MPS-1M-1	Static	MPS-1M-3	Static
Maximum Tensile T	111 N [25 lbs]	Maximum Tensile T	222 N [50 lbs]
Maximum Compressive C	111 N [25 lbs]	Maximum Compressive C	222 N [50 lbs]
Maximum Moment M_x	3.4 Nm [30 in-lbs]	Maximum Moment M_x	6.8 Nm [60 in-lbs]
Maximum Moment M_y	2.3 Nm [20 in-lbs]	Maximum Moment M_y	4.5 Nm [40 in-lbs]
Maximum Moment M_z	2.3 Nm [20 in-lbs]	Maximum Moment M_z	4.5 Nm [40 in-lbs]
MPS-1M-2	Static	MPS-1M-4	Static
Maximum Tensile T	156 N [35 lbs]	Maximum Tensile T	311 N [70 lbs]
Maximum Compressive C	156 N [35 lbs]	Maximum Compressive C	311 N [70 lbs]
Maximum Moment M_x	4.5 Nm [40 in-lbs]	Maximum Moment M_x	9.0 Nm [80 in-lbs]
Maximum Moment M_y	3.4 Nm [30 in-lbs]	Maximum Moment M_y	5.7 Nm [50 in-lbs]
Maximum Moment M_z	3.4 Nm [30 in-lbs]	Maximum Moment M_z	5.7 Nm [50 in-lbs]



GR-LIN-45

Dimensions and technical information are subject to change without notice

MPS-2M

Miniature Rail Thruster Slide | Dimensions and Technical Specifications

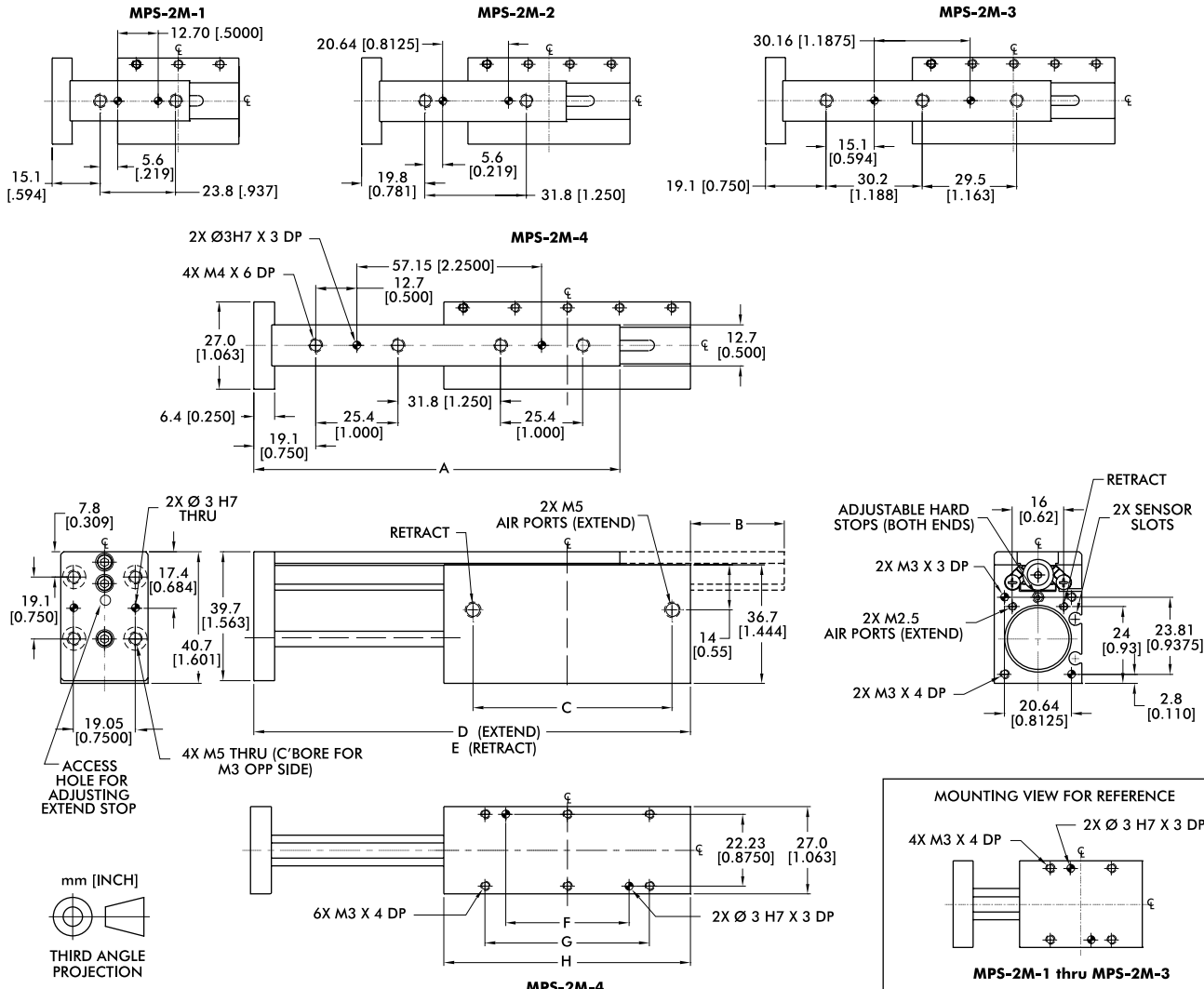

mm [INCH]
THIRD ANGLE PROJECTION

Model	A	B	C	D	E	F	G	H
MPS-2M-1	43.3 [1.704]	--	23 [0.92]	59 [2.31]	46 [1.81]	6.35 [0.2500]	19.1 [0.750]	38.1 [1.500]
MPS-2M-2	64.1 [2.524]	5.4 [0.211]	36 [1.43]	84 [3.31]	59 [2.31]	19.05 [0.7500]	31.7 [1.250]	50.8 [2.000]
MPS-2M-3	89.5 [3.524]	17.9 [0.704]	49 [1.92]	110 [4.31]	71 [2.81]	25.40 [1.0000]	38.1 [1.500]	63.5 [2.500]
MPS-2M-4	113.1 [4.454]	29.0 [1.141]	62 [2.42]	135 [5.31]	84 [3.31]	38.10 [1.5000]	50.8 [2.000]	76.2 [3.000]

Dimensions in mm [in]

Loading Information

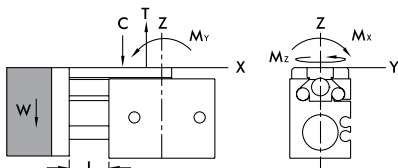

MPS-2M-1	Static	MPS-2M-3	Static
Maximum Tensile T	111 N [25 lbs]	Maximum Tensile T	222 N [50 lbs]
Maximum Compressive C	111 N [25 lbs]	Maximum Compressive C	222 N [50 lbs]
Maximum Moment M_x	3.4 Nm [30 in-lbs]	Maximum Moment M_x	6.8 Nm [60 in-lbs]
Maximum Moment M_y	2.3 Nm [20 in-lbs]	Maximum Moment M_y	4.5 Nm [40 in-lbs]
Maximum Moment M_z	2.3 Nm [20 in-lbs]	Maximum Moment M_z	4.5 Nm [40 in-lbs]
MPS-2M-2	Static	MPS-2M-4	Static
Maximum Tensile T	156 N [35 lbs]	Maximum Tensile T	311 N [70 lbs]
Maximum Compressive C	156 N [35 lbs]	Maximum Compressive C	311 N [70 lbs]
Maximum Moment M_x	4.5 Nm [40 in-lbs]	Maximum Moment M_x	9.0 Nm [80 in-lbs]
Maximum Moment M_y	3.4 Nm [30 in-lbs]	Maximum Moment M_y	5.7 Nm [50 in-lbs]
Maximum Moment M_z	3.4 Nm [30 in-lbs]	Maximum Moment M_z	5.7 Nm [50 in-lbs]

Dimensions and technical information are subject to change without notice

GR-LIN-46



MPS-1M

Miniature Rail Thruster Slide | Dimensions and Technical Specifications

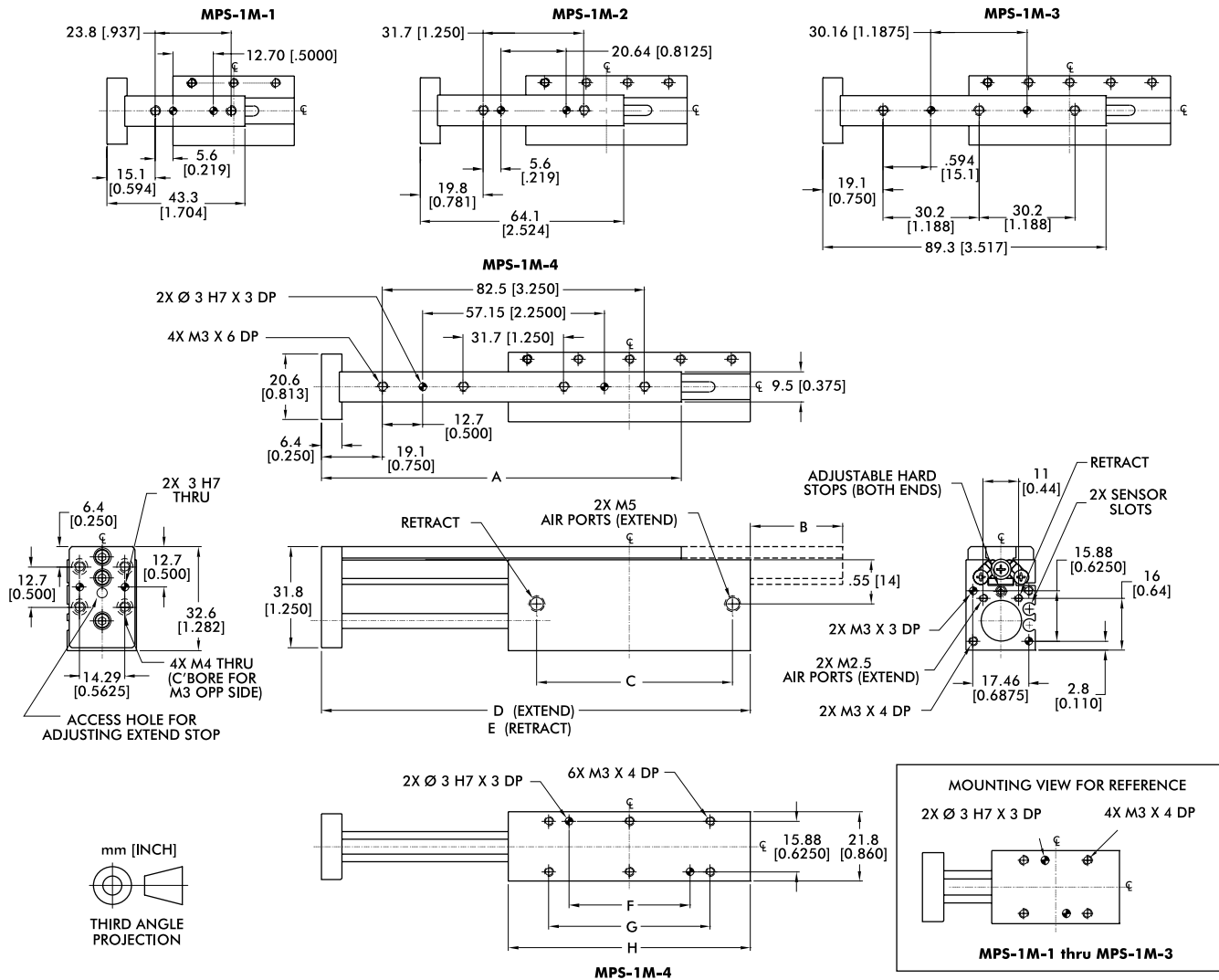

Model	A	B	C	D	E	F	G	H
MPS-1M-1	43.3 [1.704]	--	23 [0.92]	59 [2.31]	46 [1.81]	6.35 [0.2500]	19.1 [0.750]	38.1 [1.500]
MPS-1M-2	64.1 [2.524]	5.4 [0.211]	36 [1.43]	84 [3.31]	58 [2.31]	19.05 [0.7500]	31.8 [1.250]	50.8 [2.000]
MPS-1M-3	89.3 [3.517]	17.9 [0.704]	49 [1.93]	110 [4.31]	71 [2.81]	25.40 [1.0000]	38.1 [1.500]	63.5 [2.500]
MPS-1M-4	113.1 [4.454]	29.0 [1.141]	62 [2.43]	135 [5.31]	84 [3.31]	38.10 [1.5000]	50.8 [2.000]	76.2 [3.000]

Dimensions in mm [in]

Loading Information

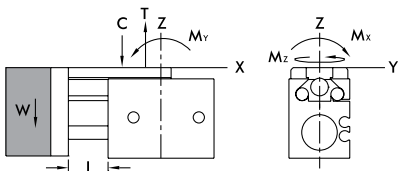

MPS-1M-1	Static	MPS-1M-3	Static
Maximum Tensile T	111 N [25 lbs]	Maximum Tensile T	222 N [50 lbs]
Maximum Compressive C	111 N [25 lbs]	Maximum Compressive C	222 N [50 lbs]
Maximum Moment M_x	3.4 Nm [30 in-lbs]	Maximum Moment M_x	6.8 Nm [60 in-lbs]
Maximum Moment M_y	2.3 Nm [20 in-lbs]	Maximum Moment M_y	4.5 Nm [40 in-lbs]
Maximum Moment M_z	2.3 Nm [20 in-lbs]	Maximum Moment M_z	4.5 Nm [40 in-lbs]
MPS-1M-2	Static	MPS-1M-4	Static
Maximum Tensile T	156 N [35 lbs]	Maximum Tensile T	311 N [70 lbs]
Maximum Compressive C	156 N [35 lbs]	Maximum Compressive C	311 N [70 lbs]
Maximum Moment M_x	4.5 Nm [40 in-lbs]	Maximum Moment M_x	9.0 Nm [80 in-lbs]
Maximum Moment M_y	3.4 Nm [30 in-lbs]	Maximum Moment M_y	5.7 Nm [50 in-lbs]
Maximum Moment M_z	3.4 Nm [30 in-lbs]	Maximum Moment M_z	5.7 Nm [50 in-lbs]



GR-LIN-45

Dimensions and technical information are subject to change without notice

MPS-2M

Miniature Rail Thruster Slide | Dimensions and Technical Specifications

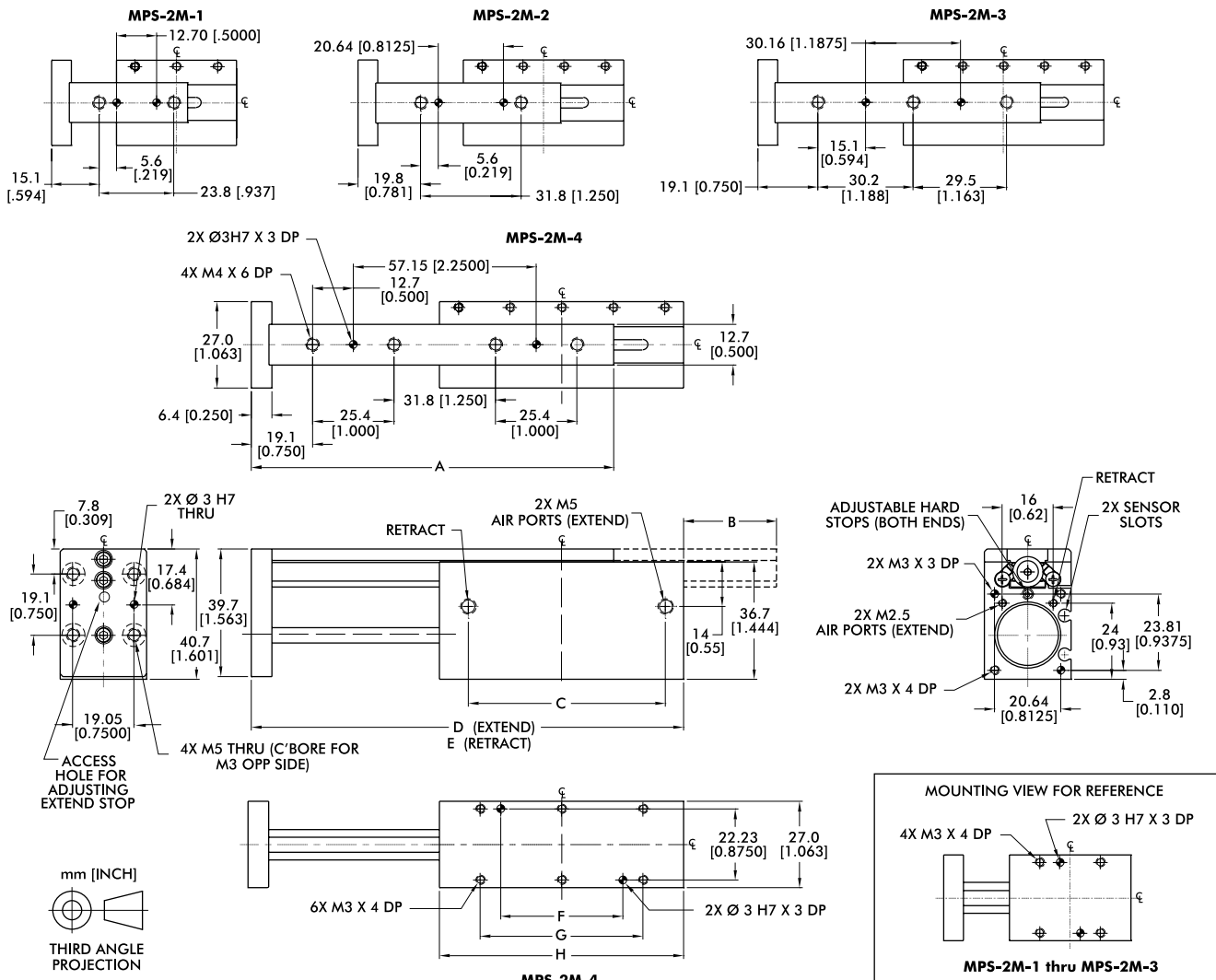

Model	A	B	C	D	E	F	G	H
MPS-2M-1	43.3 [1.704]	--	23 [0.92]	59 [2.31]	46 [1.81]	6.35 [0.2500]	19.1 [0.750]	38.1 [1.500]
MPS-2M-2	64.1 [2.524]	5.4 [0.211]	36 [1.43]	84 [3.31]	59 [2.31]	19.05 [0.7500]	31.7 [1.250]	50.8 [2.000]
MPS-2M-3	89.5 [3.524]	17.9 [0.704]	49 [1.92]	110 [4.31]	71 [2.81]	25.40 [1.0000]	38.1 [1.500]	63.5 [2.500]
MPS-2M-4	113.1 [4.454]	29.0 [1.141]	62 [2.42]	135 [5.31]	84 [3.31]	38.10 [1.5000]	50.8 [2.000]	76.2 [3.000]

Dimensions in mm [in]

Loading Information

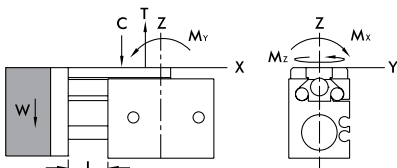

Model	Static	Model	Static		
MPS-2M-1	Maximum Tensile T	111 N [25 lbs]	MPS-2M-3	Maximum Tensile T	222 N [50 lbs]
	Maximum Compressive C	111 N [25 lbs]		Maximum Compressive C	222 N [50 lbs]
	Maximum Moment M_x	3.4 Nm [30 in-lbs]		Maximum Moment M_x	6.8 Nm [60 in-lbs]
	Maximum Moment M_y	2.3 Nm [20 in-lbs]		Maximum Moment M_y	4.5 Nm [40 in-lbs]
	Maximum Moment M_z	2.3 Nm [20 in-lbs]		Maximum Moment M_z	4.5 Nm [40 in-lbs]
MPS-2M-2	Maximum Tensile T	156 N [35 lbs]	MPS-2M-4	Maximum Tensile T	311 N [70 lbs]
	Maximum Compressive C	156 N [35 lbs]		Maximum Compressive C	311 N [70 lbs]
	Maximum Moment M_x	4.5 Nm [40 in-lbs]		Maximum Moment M_x	9.0 Nm [80 in-lbs]
	Maximum Moment M_y	3.4 Nm [30 in-lbs]		Maximum Moment M_y	5.7 Nm [50 in-lbs]
	Maximum Moment M_z	3.4 Nm [30 in-lbs]		Maximum Moment M_z	5.7 Nm [50 in-lbs]

Dimensions and technical information are subject to change without notice

GR-LIN-46

